

# MATHEMATICS

## *NATIONAL 5 NOTES*

$\times$

$\pm$

$\div$

$$A = \pi r^2$$

$\leq$

$\Sigma$

$x$

$\pi$

$$V = l b h$$

$\sqrt{\quad}$

$+$

$-$

## INDEX:

page 1	Chapter 1: Fractions
page 3	Chapter 2: Percentages
page 5	Chapter 3: Surds
page 7	Chapter 4: Indices, including Scientific Notation and Significant Figures
page 9	Chapter 5: Volumes of Solids
page 11	Chapter 6: Pythagoras' Theorem
page 13	Chapter 7: Similar Shapes
page 15	Chapter 8: Angles and Shape
page 17	Chapter 9: Properties of the Circle
page 19	Chapter 10: Arcs and Sectors
page 20	Chapter 11: Algebraic Expressions
page 24	Chapter 12: Equations and Inequalities, including Transposing Formulae
page 27	Chapter 13: Straight Line, including scatter diagram
page 30	Chapter 14: Simultaneous Equations
page 33	Chapter 15: Quadratic Equations
page 40	Chapter 16: Trigonometry: Right-Angled Triangles
page 42	Chapter 17: Trigonometry: Graphs and Equations
page 48	Chapter 18: Trigonometry: Triangle Formulae
page 51	Chapter 19: Vectors
page 53	Chapter 20: Statistics

©2013 D R Turnbull

This material may be used for non-profit educational purposes only and must include this copyright notice.

## FORMULAE LIST

The roots of  $ax^2 + bx + c = 0$  are  $x = \frac{-b \pm \sqrt{b^2 - 4ac}}{2a}$ ,  $a \neq 0$

Sine rule:  $\frac{a}{\sin A} = \frac{b}{\sin B} = \frac{c}{\sin C}$

Cosine rule:  $a^2 = b^2 + c^2 - 2bc \cos A$  or  $\cos A = \frac{b^2 + c^2 - a^2}{2bc}$

Area of a triangle:  $\text{Area} = \frac{1}{2}ab \sin C$

Volume of a sphere:  $\text{Volume} = \frac{4}{3}\pi r^3$

Volume of a cone:  $\text{Volume} = \frac{1}{3}\pi r^2 h$

Volume of a pyramid:  $\text{Volume} = \frac{1}{3}Ah$

Volume of a cylinder:  $\text{Volume} = \pi r^2 h$

Standard deviation:  $s = \sqrt{\frac{\sum(x - \bar{x})^2}{n-1}} = \sqrt{\frac{\sum x^2 - (\sum x)^2/n}{n-1}}$ , where  $n$  is the sample size.

# CHAPTER 1: FRACTIONS

**Simplify** (cancel down):

$$\frac{28}{36} = \frac{28 \div 4}{36 \div 4} = \frac{7}{9}$$

divide by **highest common factor**,  $HCF(28,36) = 4$

**Mixed numbers and improper fractions** (top heavy):

$$\overbrace{4 \times 2 + 3 = 11} \rightarrow$$

$$2\frac{3}{4} = 2 + \frac{3}{4} = \frac{8}{4} + \frac{3}{4} = \frac{11}{4} \quad \text{'bottom' stays as 4}$$

$$\leftarrow \overbrace{11 \div 4 = 2 \text{ R}3}$$

**Addition and Subtraction** requires a common denominator:

$$\begin{aligned} & \frac{5}{6} - \frac{4}{9} && \text{least common multiple } LCM(6,9)=18 \\ & \frac{5 \times 3}{6 \times 3} = \frac{15}{18} && \frac{4 \times 2}{9 \times 2} = \frac{8}{18} && \text{both fractions now 18ths} \\ & = \frac{15}{18} - \frac{8}{18} \\ & = \frac{7}{18} && \text{subtract 'top' numbers, still 18ths} \end{aligned}$$

**Multiplication and Division** requires **no** mixed numbers:

$$\frac{a}{b} \times \frac{c}{d} = \frac{a \times c}{b \times d}$$

$$\frac{a}{b} \div \frac{c}{d} = \frac{a}{b} \times \frac{d}{c}$$

$$\frac{3}{10} \times 2\frac{3}{4}$$

$$\frac{4}{5} \div \frac{7}{8}$$

$$= \frac{3}{10} \times \frac{11}{4} \quad \text{go 'top heavy'}$$

$$= \frac{4}{5} \times \frac{8}{7} \quad \text{multiply by reciprocal}$$

$$= \frac{33}{40}$$

$$= \frac{32}{35}$$

**ORDER OF CALCULATION:**  $\times$  and  $\div$  before  $+$  or  $-$   
*to change the order use brackets* **BRACKETS FIRST!**

**Carry out separate calculations:**

(1)  $7\frac{5}{6} - \frac{8}{9}$  of  $2\frac{3}{4}$

*multiply first*

$$\begin{aligned} & \frac{8}{9} \times \frac{11}{4} \quad \text{of means multiply} \\ & = \frac{88}{36} \quad \text{fully simplify} \\ & = \frac{22}{9} \\ & = 2\frac{4}{9} \end{aligned}$$

*subtraction last*

$$\begin{aligned} & 7\frac{5}{6} - 2\frac{4}{9} \\ & = 7\frac{15}{18} - 2\frac{8}{18} \quad \text{common denominator} \\ & = 5\frac{7}{18} \quad \text{subtract whole numbers and} \\ & \quad \quad \quad \text{fractions separately} \end{aligned}$$

(2)  $\left(\frac{5}{6} - \frac{1}{2}\right) \div 1\frac{3}{4}$

$$\begin{aligned} & \frac{5}{6} - \frac{1}{2} \quad \text{brackets first} \\ & = \frac{5}{6} - \frac{3}{6} \\ & = \frac{2}{6} \quad \text{fully simplify} \\ & = \frac{1}{3} \end{aligned}$$

$$\begin{aligned} & \frac{1}{3} \div 1\frac{3}{4} \\ & = \frac{1}{3} \div \frac{7}{4} \quad \text{'top-heavy' first} \\ & = \frac{1}{3} \times \frac{4}{7} \quad \text{multiply by reciprocal} \\ & = \frac{4}{21} \end{aligned}$$

# CHAPTER 2: PERCENTAGES

## PERCENTAGE CHANGE

	original value	changed value
INCREASE: growth, appreciation, compound interest	$100\%$	$100\% \xrightarrow{+a\%} (100 + a)\%$
DECREASE: decay, depreciation	$100\%$	$100\% \xrightarrow{-a\%} (100 - a)\%$

For example,

8% increase:  $100\% \xrightarrow{+8\%} 108\% = 1.08$  multiply quantity by 1.08 for 8% increase

8% decrease:  $100\% \xrightarrow{-8\%} 92\% = 0.92$  multiply quantity by 0.92 for 8% decrease

## REVERSING PERCENTAGE CHANGE

Divide by the factor which produced the increase.

(1) Including VAT of 20%, a radio costs £96. Find the original cost exclusive of VAT.

<i>20% VAT added</i>	$£x \times 1.20 = £96$
$100\% \xrightarrow{+20\%} 120\% = 1.20$	$£x = £96 \div 1.20$
	$= £80$

**non-calculator:**  $120\% \xrightarrow{\div 12} 10\% \xrightarrow{\times 10} 100\%$   
 $£96 \div 12 = £8$        $£8 \times 10 = £80$

(2) A camera costs £120 after a discount of 25% is applied. Find the original cost.

<i>25% discount subtracted</i>	$£x \times 0.75 = £120$
$100\% \xrightarrow{-25\%} 075\% = 0.75$	$£x = £120 \div 0.75$
	$= £160$

**non-calculator:**  $75\% = \frac{3}{4}$        $\frac{3}{4} \xrightarrow{\div 3} \frac{1}{4} \xrightarrow{\times 4} \frac{4}{4}$   
 $£120 \div 3 = £40$        $£40 \times 4 = £160$

## COMPOUND PERCENTAGE CHANGE

### appreciation and depreciation

(1) A £240000 house appreciates in value by 5% in 2007, appreciates 10% in 2008 and depreciates by 15% in 2009. Calculate the value of the house at the end of 2009.

5% increase:  $100\% + 5\% = 105\% = 1.05$   
10% increase:  $100\% + 10\% = 110\% = 1.10$   
15% decrease:  $100\% - 15\% = 85\% = 0.85$

$$\begin{aligned} &£240000 \times 1.05 \times 1.10 \times 0.85 \\ &= £235620 \end{aligned}$$

**OR**      *evaluate year by year*

*year 1*

5% of £240000 = £12000  
£240000 + £12000 = £252000

*year 2*

10% of £252000 = £25200  
£252000 + £25200 = £277200

*year 3*

15% of £277200 = £41580  
£277200 - £41580 = £235620

### compound interest

(2) Calculate the compound interest on £12000 invested at 5% pa for 3 years.

$£12000 \times (1.05)^3$       *ie.*  $\times 1.05 \times 1.05 \times 1.05$       *or evaluate year by year*  
 $£12000 \times 1.157625$   
 $= £13891.50$   
*compound interest* =  $£13891.50 - £12000 = £1891.50$

## EXPRESSING CHANGE AS A PERCENTAGE

$$\% \text{ change} = \frac{\text{change}}{\text{start}} \times 100\%$$

A £15000 car is resold for £12000.  
Find the percentage loss.

$$\begin{aligned} \text{loss} &= £15000 - £12000 = £3000 \\ \% \text{ loss} &= \frac{3000}{15000} \times 100\% = 20\% \end{aligned}$$

# CHAPTER 3: SURDS

## NUMBER SETS:

Natural numbers  $N = \{1, 2, 3, \dots\}$

Whole numbers  $W = \{0, 1, 2, 3, \dots\}$

Integers  $Z = \{\dots -3, -2, -1, 0, 1, 2, 3, \dots\}$

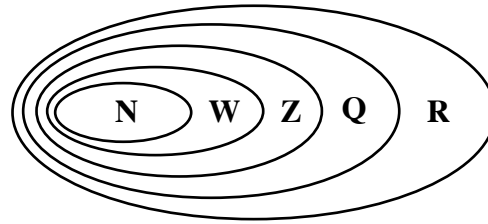

Rational numbers,  $Q$ , can be written as a division of two integers.

Irrational numbers **cannot** be written as a division of two integers.

Real numbers,  $R$ , are all rational and irrational numbers.

## SURDS ARE IRRATIONAL ROOTS.

For example,  $\sqrt{2}$ ,  $\sqrt{\frac{5}{9}}$ ,  $\sqrt[3]{16}$  are surds.

whereas  $\sqrt{25}$ ,  $\sqrt{\frac{4}{9}}$ ,  $\sqrt[3]{-8}$  are **not** surds as they are  $5$ ,  $\frac{2}{3}$  and  $-2$  respectively.

## SIMPLIFYING ROOTS:

**RULES:**  $\sqrt{mn} = \sqrt{m} \times \sqrt{n}$

$$\sqrt{\frac{m}{n}} = \frac{\sqrt{m}}{\sqrt{n}}$$

(1) Simplify  $\sqrt{24} \times \sqrt{3}$

$$\begin{aligned} & \sqrt{24} \times \sqrt{3} \\ &= \sqrt{72} \end{aligned}$$

$$= \sqrt{36} \times \sqrt{2}$$

*36 is the largest square number which is a factor of 72*

$$= 6 \times \sqrt{2}$$

$$= 6\sqrt{2}$$

(2) Simplify  $\sqrt{72} + \sqrt{48} - \sqrt{50}$

$$\begin{aligned} & \sqrt{72} + \sqrt{48} - \sqrt{50} \\ &= \sqrt{36} \times \sqrt{2} + \sqrt{16} \times \sqrt{3} - \sqrt{25} \times \sqrt{2} \end{aligned}$$

$$= 6\sqrt{2} + 4\sqrt{3} - 5\sqrt{2}$$

$$= 6\sqrt{2} - 5\sqrt{2} + 4\sqrt{3}$$

$$= \sqrt{2} + 4\sqrt{3}$$



(3) Remove the brackets and fully simplify:

(a)  $(\sqrt{3} - \sqrt{2})^2$

$$= (\sqrt{3} - \sqrt{2})(\sqrt{3} - \sqrt{2})$$

$$= \sqrt{3}(\sqrt{3} - \sqrt{2}) - \sqrt{2}(\sqrt{3} - \sqrt{2})$$

$$= \sqrt{9} - \sqrt{6} - \sqrt{6} + \sqrt{4}$$

$$= 3 - \sqrt{6} - \sqrt{6} + 2$$

$$= 5 - 2\sqrt{6}$$

(b)  $(3\sqrt{2} + 2)(3\sqrt{2} - 2)$

$$= (3\sqrt{2} + 2)(3\sqrt{2} - 2)$$

$$= 3\sqrt{2}(3\sqrt{2} - 2) + 2(3\sqrt{2} - 2)$$

$$= 9\sqrt{4} - 6\sqrt{2} + 6\sqrt{2} - 4$$

$$= 18 - 6\sqrt{2} + 6\sqrt{2} - 4$$

$$= 14$$

### RATIONALISING DENOMINATORS:

Removing surds from the denominator.

Express with a rational denominator:

(1)  $\frac{4}{\sqrt{6}}$

$$\frac{4}{\sqrt{6}}$$

$$= \frac{4 \times \sqrt{6}}{\sqrt{6} \times \sqrt{6}} \quad \text{multiply the 'top' and 'bottom'}$$

*by the surd on the denominator*

$$= \frac{4\sqrt{6}}{6}$$

$$= \frac{2\sqrt{6}}{3}$$

(2)  $\frac{\sqrt{3}}{3\sqrt{2}}$

$$\frac{\sqrt{3}}{3\sqrt{2}}$$

$$= \frac{\sqrt{3} \times \sqrt{2}}{3\sqrt{2} \times \sqrt{2}}$$

$$= \frac{\sqrt{6}}{3 \times \sqrt{4}}$$

$$= \frac{\sqrt{6}}{6}$$

## CHAPTER 4: INDICES

base  $\longrightarrow$   $a^n$   $\longleftarrow$  index or exponent

**INDICES RULES:** require the same base.

**Examples:**

$$a^m \times a^n = a^{m+n}$$

$$\frac{w^2 \times w^5}{w^3} = \frac{w^7}{w^3} = w^4$$

$$a^m \div a^n = a^{m-n}$$

$$(a^m)^n = a^{mn}$$

$$(3^5)^2 = 3^{10}$$

$$(ab)^n = a^n b^n$$

$$(2a^3b)^2 = 2^2 a^6 b^2 = 4a^6 b^2$$

$$a^0 = 1$$

$$5^0 = 1$$

$$a^1 = a$$

$$5^1 = 5$$

$$a^{\frac{m}{n}} = \sqrt[n]{a^m} = (\sqrt[n]{a})^m$$

$$8^{\frac{4}{3}} = (\sqrt[3]{8})^4 = 2^4 = 16$$

$$\frac{1}{a^p} = a^{-p}$$

$$8^{-\frac{4}{3}} = \frac{1}{8^{\frac{4}{3}}} = \frac{1}{16}$$

## SCIENTIFIC NOTATION (STANDARD FORM)

Writing numbers in the form  $a \times 10^n$

where  $1 \leq a < 10$       *place the decimal point after the first non-zero digit*  
and  $n$  is an integer      *numbers ...-3, -2, -1, 0, 1, 2, 3...*

$$32800 = 3 \cdot 28 \times 10 \times 10 \times 10 \times 10 = 3 \cdot 28 \times 10^4$$

$$0 \cdot 000328 = 3 \cdot 28 \div 10 \div 10 \div 10 \div 10 = 3 \cdot 28 \div 10^4 = 3 \cdot 28 \times 10^{-4}$$

Notice for numbers starting  $0 \cdot$  the power of 10 is negative (same as  $\div 10$ ).

**SIGNIFICANT FIGURES** indicate the accuracy of a **measurement**.

For example,       $3400 \text{ cm} = 34 \text{ m} = 0 \cdot 034 \text{ km}$   
   same measurement, same accuracy, each 2 significant figures.

Count the number of figures used, but **not** zeros at the **end** of a whole number  
or zeros at the **start** of a decimal.

**rounding:**     $5713 \cdot 4$                        $5700$  to 2 significant figures  
    $0 \cdot 057134$                        $0 \cdot 057$  to 2 significant figures    (note:  $0 \cdot 057000$  wrong)

- (1) One **milligram** of hydrogen gas contains  $2 \cdot 987 \times 10^{20}$  molecules.  
Calculate, to 3 significant figures, the number of molecules in **5 grams** of hydrogen.

$$\begin{aligned} & 5000 \times 2 \cdot 987 \times 10^{20} \quad \text{learn to enter standard form in the calculator using the} \\ & = 1 \cdot 4935 \times 10^{24} \quad \text{appropriate button EE or EXP or } \times 10^n \quad \text{eg. } 2 \cdot 987 \text{ EXP } 20 \\ & \approx 1 \cdot 49 \times 10^{24} \text{ molecules} \end{aligned}$$

- (2) The total mass of argon in a flask is  $4 \cdot 15 \times 10^{-2}$  grams.  
The mass of a single atom of argon is  $6 \cdot 63 \times 10^{-23}$  grams.  
Find, correct to 3 significant figures, the number of argon atoms in the flask.

$$\begin{aligned} & \frac{4 \cdot 15 \times 10^{-2}}{6 \cdot 63 \times 10^{-23}} \quad \text{use the } (-) \text{ button for a minus eg. } 4 \cdot 15 \text{ EXP } (-) 2 \\ & = 6 \cdot 259 \dots \times 10^{20} \quad \text{divide 'top' by 'bottom' and write the unrounded answer} \\ & \approx 6 \cdot 26 \times 10^{20} \text{ atoms} \quad \text{write the rounded answer} \end{aligned}$$

# CHAPTER 5: VOLUMES OF SOLIDS

**PRISMS** a solid with the same cross-section throughout its length.  
length  $l$  is at right-angles to the area  $A$ .

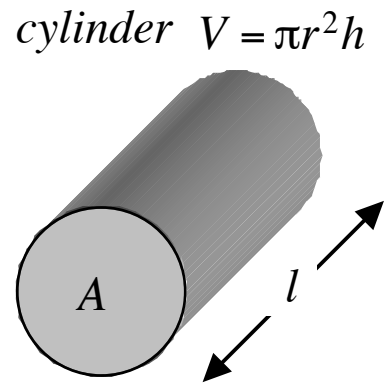
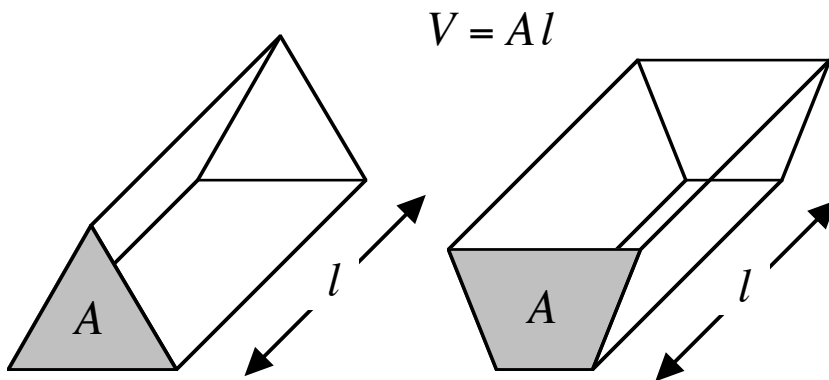

## PYRAMIDS

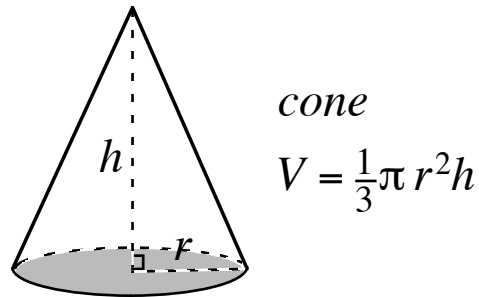
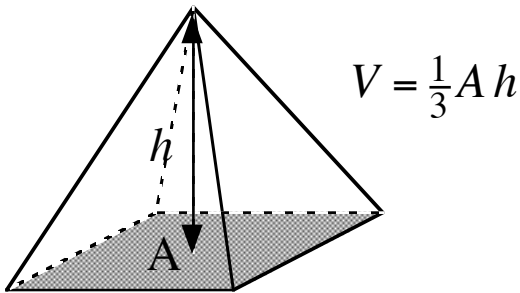

## SPHERE

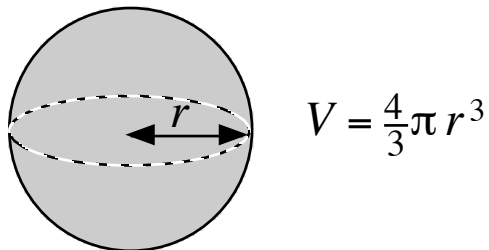

## EFFECT OF CHANGE

Describe the effect on the volume of a cylinder of:

- (i) trebling the radius
- (ii) doubling the radius and halving the height

$$\begin{aligned}
 V &= \pi(3r)^2 h \\
 &= \pi 9r^2 h \\
 &= 9\pi r^2 h \\
 &9 \text{ times bigger}
 \end{aligned}$$

$$\begin{aligned}
 V &= \pi(2r)^2 \left(\frac{1}{2}h\right) \\
 &= \pi 4r^2 \times \frac{1}{2}h \\
 &= 2\pi r^2 h \\
 &2 \text{ times bigger}
 \end{aligned}$$

## USING THE FORMULAE

(1) Calculate the volume.

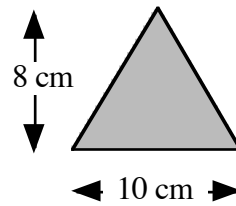
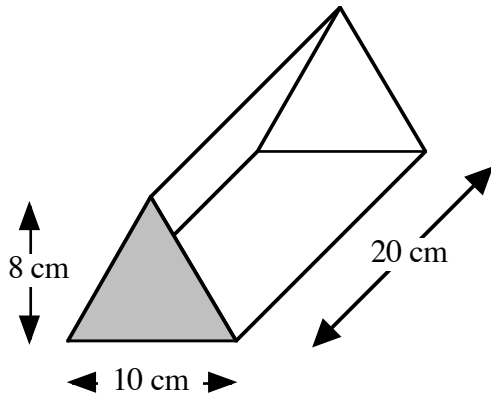

$$\begin{aligned} A &= \frac{1}{2}bh \\ &= 10 \times 8 \div 2 \\ &= 40 \text{ cm}^2 \end{aligned}$$

$$\begin{aligned} V &= Al \\ &= 40 \times 20 \\ &= 800 \text{ cm}^3 \end{aligned}$$

(2) Calculate the volume correct to **3 significant figures**.

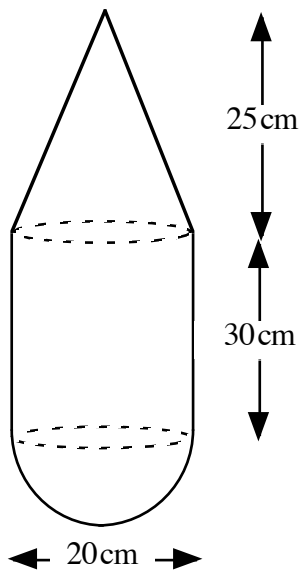

$$\text{radius} = 20\text{cm} \div 2 = 10\text{cm}$$

$$\begin{aligned} V &= \frac{1}{3}\pi r^2 h \\ &= \frac{1}{3} \times \pi \times 10 \times 10 \times 25 \\ &= 2617.993... \text{ cm}^3 \end{aligned}$$

$$\begin{aligned} V &= \pi r^2 h \\ &= \pi \times 10 \times 10 \times 30 \\ &= 9424.777... \text{ cm}^3 \end{aligned}$$

$$\begin{aligned} V &= \frac{4}{3}\pi r^3 \div 2 \\ &= \frac{4}{3} \times \pi \times 10 \times 10 \times 10 \div 2 \\ &= 2094.395... \text{ cm}^3 \end{aligned}$$

$$\begin{aligned} \text{total volume} &= 2617.993... + 9424.777... + 2094.395... \\ &= 14137.166... \\ &\approx 14100 \text{ cm}^3 \end{aligned}$$

# CHAPTER 6: PYTHAGORAS' THEOREM

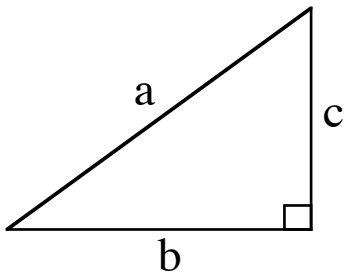

Side length **a** units is opposite the right angle. It is the longest side, the **hypotenuse**.

For **right-angled triangles**:

$$a^2 = b^2 + c^2$$

**3D** Identify right-angled triangles in 3D diagrams.

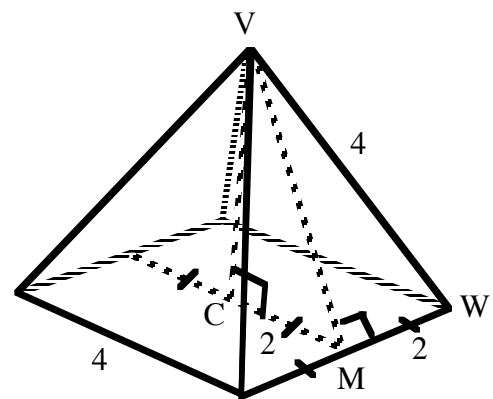
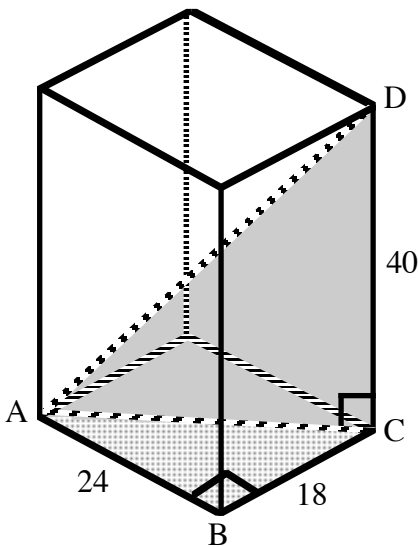

*face diagonal*  $AC^2 = 24^2 + 18^2$   
 $= 576 + 324$   
 $= 900$   
 $AC = \sqrt{900}$   
 $= 30$

*slant height*  $VM^2 = 4^2 - 2^2$   
 $= 16 - 4$   
 $= 12$   
 $VM = \sqrt{12}$   
 $= 2\sqrt{3}$

*space diagonal*  $AD^2 = 40^2 + 30^2$   
 $= 1600 + 900$   
 $= 2500$   
 $AD = \sqrt{2500}$   
 $= 50$

*height*  $VC^2 = (\sqrt{12})^2 - 2^2$   
 $= 12 - 4$   
 $= 8$   
 $VC = \sqrt{8}$   
 $= 2\sqrt{2}$

## CONVERSE OF PYTHAGORAS' THEOREM

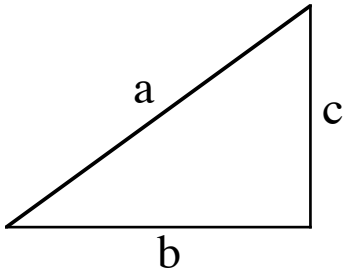

Longest side, length **a** units, is opposite the biggest angle.

If  $a^2 = b^2 + c^2$

then the triangle is right-angled

Show that  $\triangle ABC$  is right angled.

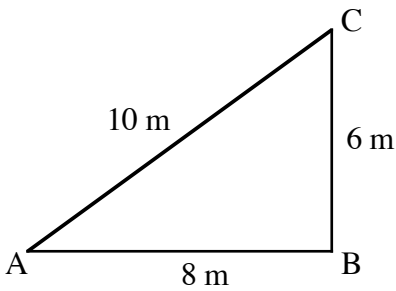

$$AB^2 + BC^2 = 8^2 + 6^2 = 100$$

$$AC^2 = 10^2 = 100$$

$$\text{since } AB^2 + BC^2 = AC^2$$

by the Converse of Pyth. Thm.

$\triangle ABC$  is right - angled at B (ie.  $\angle ABC = 90^\circ$ )

# CHAPTER 7: SIMILAR SHAPES

Shapes are similar if they are enlargement or reductions of each other.

- and
- (1) the angles remain unchanged - the shapes are **equiangular**.
  - (2) the sides are enlarged or reduced by some **scale factor (SF)**.

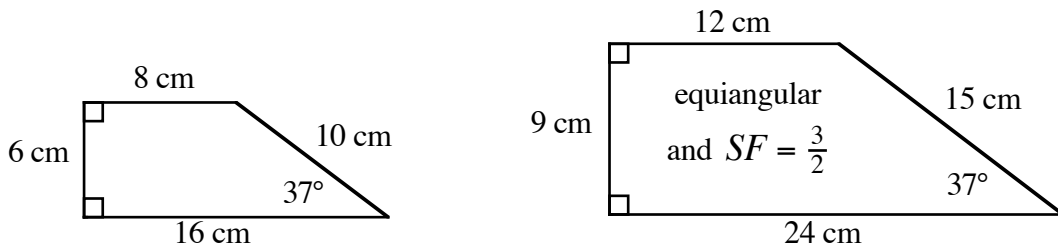

## Triangles are special:

Enlarge or reduce sides by some scale factor and the two triangles will be equiangular.

**If triangles are equiangular then they are similar.**

## SCALING LENGTH

length scale factor,  $SF = \frac{\text{image side}}{\text{original side}}$

enlargement if  $SF > 1$

reduction if  $0 < SF < 1$

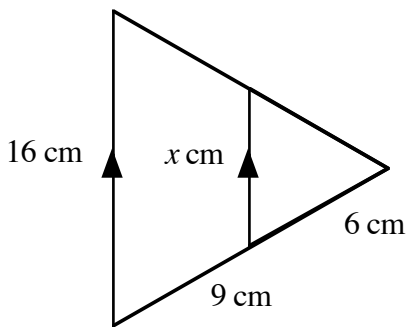

Find the value of  $x$ .

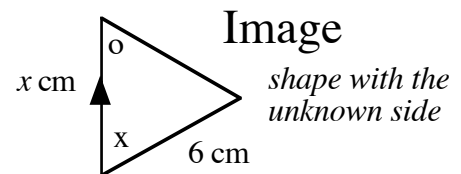
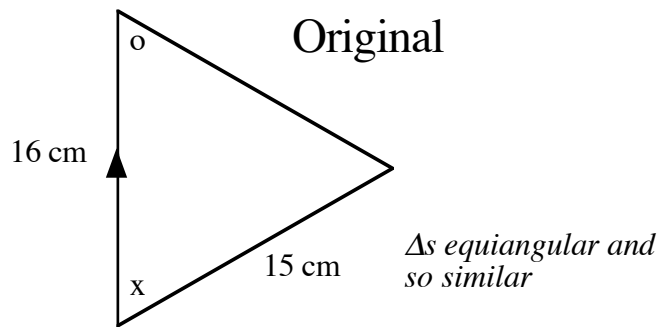

$$SF = \frac{\text{image}}{\text{original}} = \frac{6}{15} = \frac{2}{5} \quad 0 < SF < 1 \text{ as expected for a reduction}$$

$$x = \frac{2}{5} \times 16 = 6.4 \quad \text{smaller than 16 as expected for a reduction}$$



### SCALING AREA

for a 2D shape both length and breadth must be scaled.

$$\text{length SF} = n$$

$$\text{area SF} = n^2$$

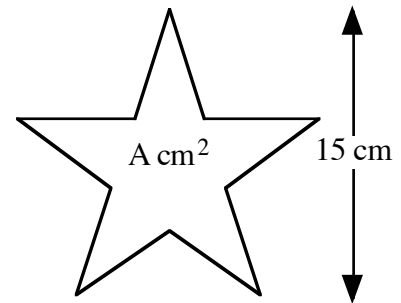
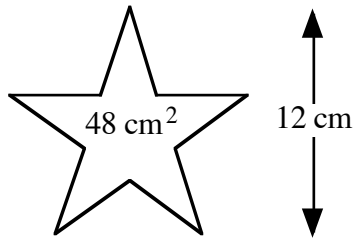

Given that the two shapes shown are similar, find the area of the larger shape.

$$\text{length SF} = \frac{\text{image}}{\text{original}} = \frac{15}{12} = \frac{5}{4}$$

$SF > 1$  as expected for an enlargement

$$\text{area SF} = \frac{5}{4} \times \frac{5}{4} = \frac{25}{16}$$

$$A = \frac{25}{16} \times 48 = 75$$

bigger than 48 as expected for an enlargement

### SCALING VOLUME

for a 3D shape length, breadth and height must be scaled.

$$\text{length SF} = n$$

$$\text{volume SF} = n^3$$

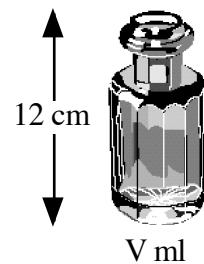
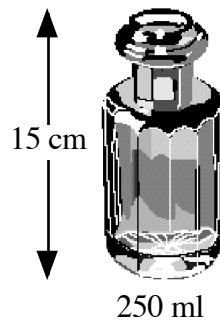

Given that the two solids shown are similar find the volume of the smaller solid.

$$\text{length SF} = \frac{\text{image}}{\text{original}} = \frac{12}{15} = \frac{4}{5}$$

$0 < SF < 1$  as expected for a reduction

$$\text{volume SF} = \frac{4}{5} \times \frac{4}{5} \times \frac{4}{5} = \frac{64}{125}$$

$$V = \frac{64}{125} \times 250 = 128$$

smaller than 250 as expected for a reduction

# CHAPTER 8: ANGLES and SHAPE

## LINES

SUPPLEMENTARY angles  
 $a + b = 180$

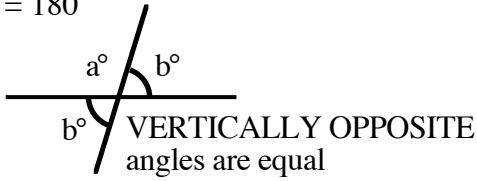

COMPLEMENTARY angles  
 $c + d = 90$

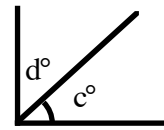

for parallel lines:

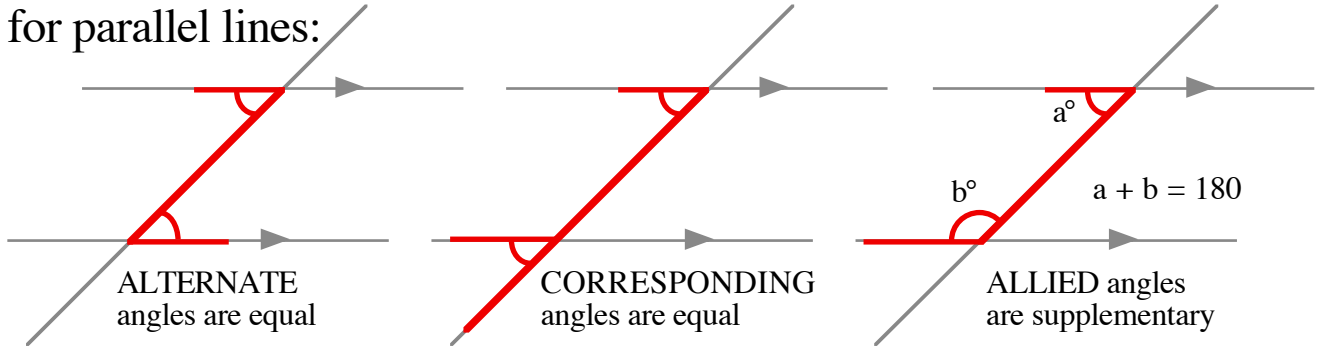

## TRIANGLES

angle sum  $a^\circ + b^\circ + c^\circ = 180^\circ$

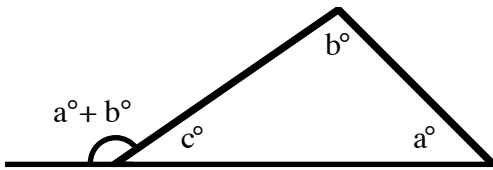

EXTERIOR ANGLE is the sum of the opposite INTERIOR ANGLES

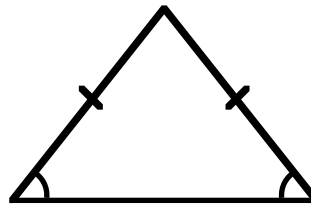

ISOSCELES

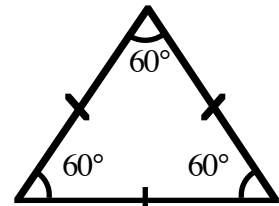

EQUILATERAL

## POLYGONS

INTERIOR ANGLES sum to  $(n-2) \times 180^\circ$  where n sides

EXTERIOR ANGLES sum to  $360^\circ$

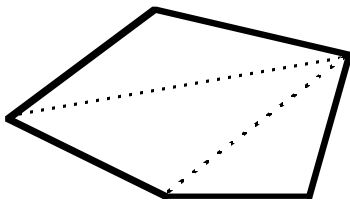

pentagon

interior sum  $3 \times 180^\circ = 540^\circ$

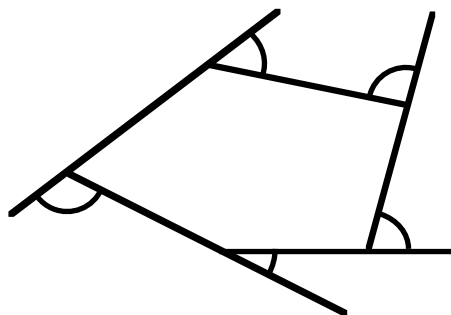

exterior sum  $360^\circ$

all sides and angles equal

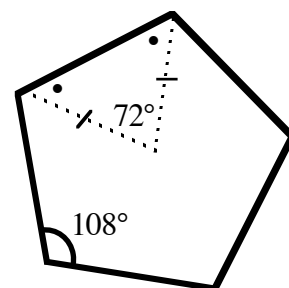

REGULAR pentagon

interior angle  $540^\circ \div 5 = 108^\circ$

**QUADRILATERALS**

**KITE**

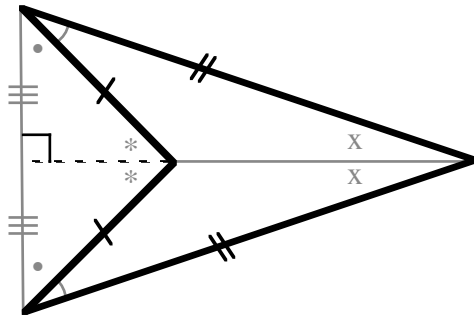
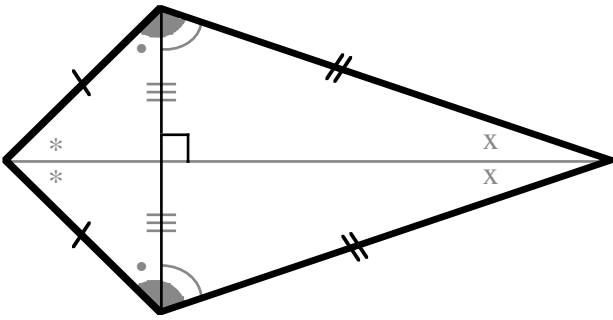

**TRAPEZIUM**

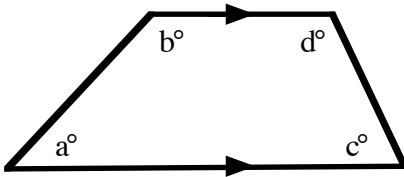

$a + b = 180$  ,  $c + d = 180$

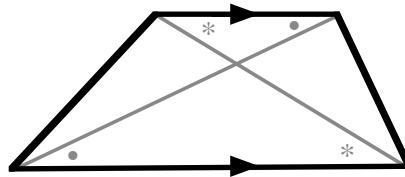

**PARALLELOGRAM** a trapezium

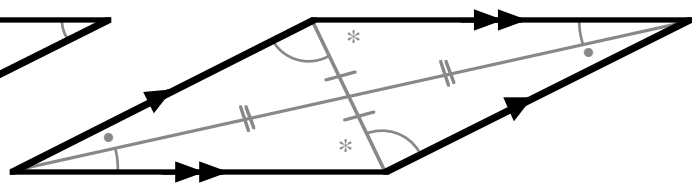
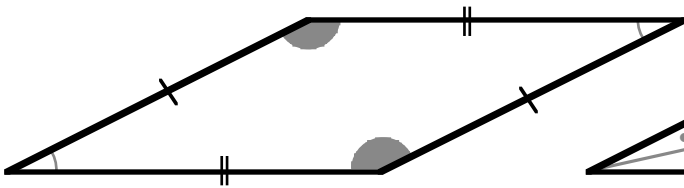

**RHOMBUS** a kite and parallelogram

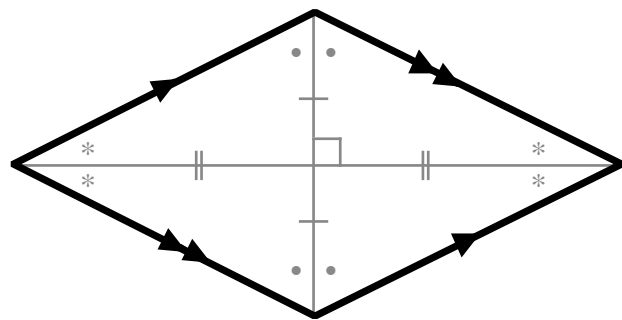
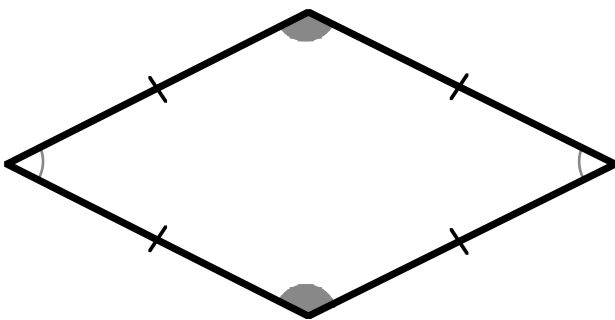

**RECTANGLE** a parallelogram

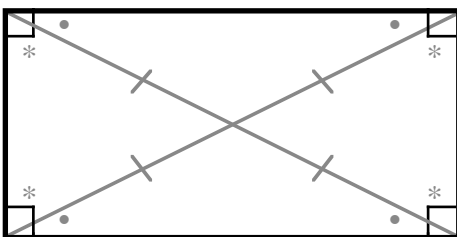

**SQUARE** a rectangle and rhombus.

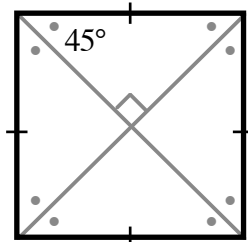

# CHAPTER 9: PROPERTIES OF THE CIRCLE

angle in a semicircle is a right-angle.

the perpendicular bisector of a chord is a diameter.

a tangent and the radius drawn to the point of contact form a right-angle.

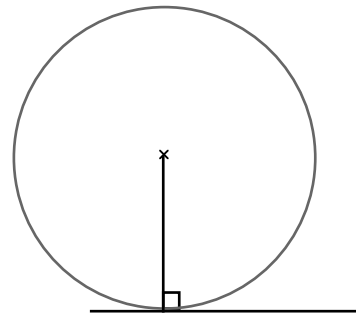
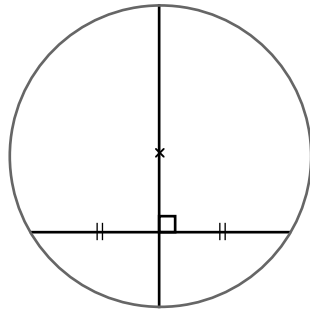
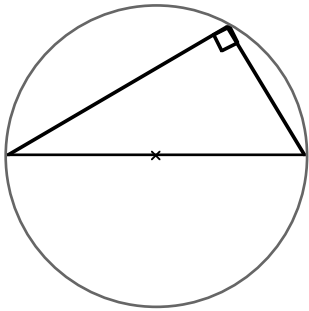

## ANGLES

(1)

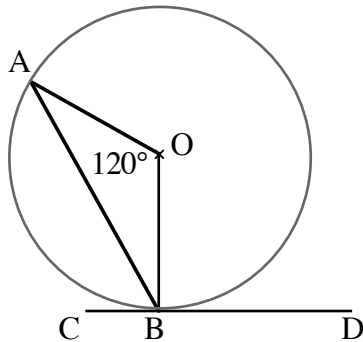

*radius  $OA = OB$  so  $\triangle AOB$  is isosceles and  $\triangle$  angle sum  $180^\circ$  :*

$$\angle OBA = (180^\circ - 120^\circ) \div 2 = 30^\circ$$

*tangent  $CD$  and radius  $OB$  :  $\angle OBC = 90^\circ$*

Calculate the size of angle ABC.

$$\angle ABC = 90^\circ - 30^\circ = 60^\circ$$

(2)

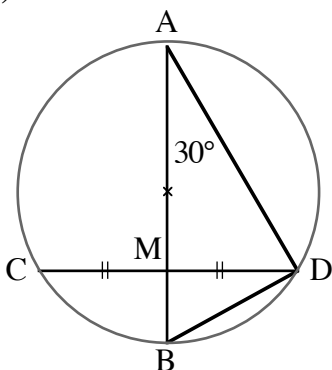

*diameter  $AB$  bisects chord  $CD$  :  $\angle AMD = 90^\circ$*

*$\triangle AMD$  angle sum  $180^\circ$  :*

$$\angle ADM = 180^\circ - 90^\circ - 30^\circ = 60^\circ$$

*angle in a semicircle :  $\angle ADB = 90^\circ$*

Calculate the size of angle BDC.

$$\angle BDC = 90^\circ - 60^\circ = 30^\circ$$

## PYTHAGORAS' THEOREM

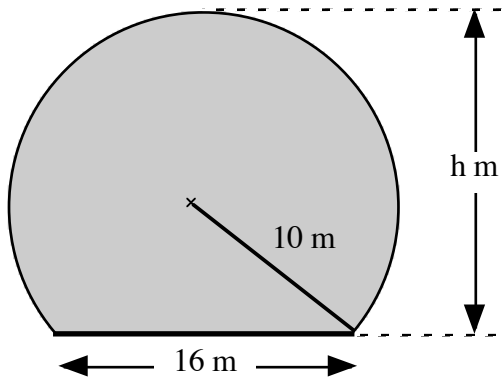

A circular road tunnel, radius 10 metres, is cut through a hill.

The road has a width 16 metres.

Find the height of the tunnel.

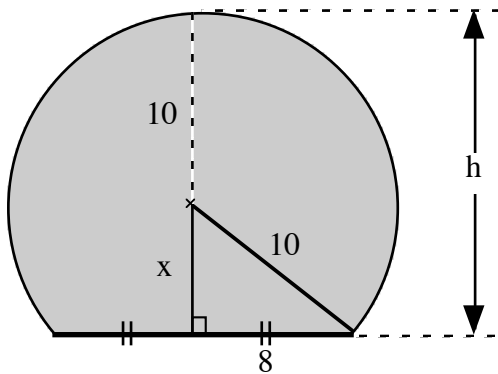

*the diameter drawn is the perpendicular bisector of the chord:  
 $\Delta$  is right-angled so can apply Pyth. Thm.*

$$\begin{aligned}x^2 &= 10^2 - 8^2 \\ &= 100 - 64 \\ &= 36\end{aligned}$$

$$x = \sqrt{36}$$

$$x = 6$$

$$h = x + 10$$

$$= 6 + 10$$

$$h = 16$$

height 16 metres

# CHAPTER 10: ARCS and SECTORS

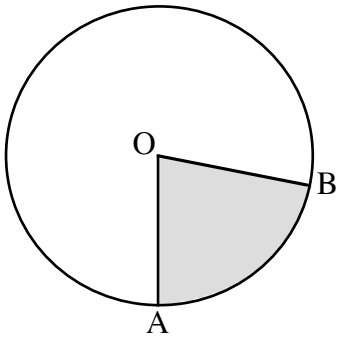

$$\frac{\angle AOB}{360^\circ} = \frac{\text{arc } AB}{\pi d} = \frac{\text{area of sector } AOB}{\pi r^2}$$

Choose the appropriate pair of ratios based on:

- (i) the ratio which includes the quantity to be found
- (ii) the ratio for which both quantities are known (or can be found).

(1) Find the **exact** length of **major** arc AB.

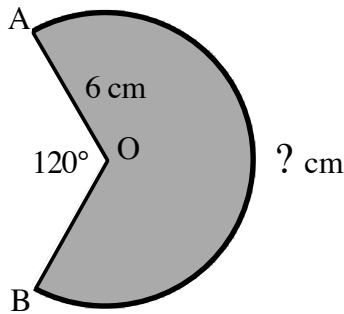

$$\frac{\angle AOB}{360^\circ} = \frac{\text{arc } AB}{\pi d}$$

$$\frac{240^\circ}{360^\circ} = \frac{\text{arc } AB}{\pi \times 12}$$

$$\begin{aligned} \text{arc } AB &= \frac{240^\circ}{360^\circ} \times \pi \times 12 \\ &= 8\pi \text{ cm} \quad (25.132\dots) \end{aligned}$$

diameter  $d = 2 \times 6 \text{ cm} = 12 \text{ cm}$

reflex  $\angle AOB = 360^\circ - 120^\circ = 240^\circ$

(2) Find the **exact** area of sector AOB.

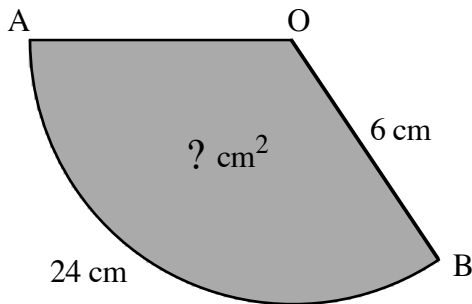

$$\frac{\text{arc } AB}{\pi d} = \frac{\text{area of sector } AOB}{\pi r^2}$$

$$\frac{24}{\pi \times 12} = \frac{\text{area of sector } AOB}{\pi \times 6 \times 6}$$

$$\begin{aligned} \text{area of sector } AOB &= \frac{24}{\pi \times 12} \times \pi \times 6 \times 6 \\ &= 72 \text{ cm}^2 \end{aligned}$$

# CHAPTER 11: ALGEBRAIC EXPRESSIONS

## REMOVING BRACKETS

### SINGLE BRACKETS

$$(1) \quad 3x(2x - y + 7) \\ = 6x^2 - 3xy + 21x$$

$$\begin{aligned} 3x \times 2x &= 6x^2 \\ 3x \times -y &= -3xy \\ 3x \times +7 &= +21x \end{aligned}$$

$$(2) \quad -2(3t + 5) \\ = -6t - 10$$

$$\begin{aligned} -2 \times 3t &= -6t \\ -2 \times +5 &= -10 \end{aligned}$$

$$(3) \quad -3w(w^2 - 4) \\ = -3w^3 + 12w$$

$$\begin{aligned} -3w \times w^2 &= -3w^3 \\ -3w \times -4 &= +12w \end{aligned}$$

Fully simplify:

$$(4) \quad 2t(3 - t) + 5t^2 \\ = 6t - 2t^2 + 5t^2 \\ = 6t + 3t^2$$

$$(5) \quad 5 - 3(n - 2) \\ = 5 - 3n + 6 \\ = 5 + 6 - 3n \\ = 11 - 3n$$

### DOUBLE BRACKETS

$$(1) \quad (3x + 2)(2x - 5) \\ = 3x(2x - 5) + 2(2x - 5) \\ = 6x^2 - 15x + 4x - 10 \\ = 6x^2 - 11x - 10$$

or

“FOIL”

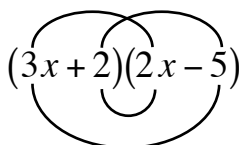

$$(2) \quad (2t - 3)^2 \\ = (2t - 3)(2t - 3) \\ = 2t(2t - 3) - 3(2t - 3) \\ = 4t^2 - 6t - 6t + 9 \\ = 4t^2 - 12t + 9$$

$$(3) \quad (w + 2)(w^2 - 3w + 5) \\ = w(w^2 - 3w + 5) + 2(w^2 - 3w + 5) \\ = w^3 - 3w^2 + 5w + 2w^2 - 6w + 10 \\ = w^3 - 3w^2 + 2w^2 + 5w - 6w + 10 \\ = w^3 - w^2 - w + 10$$

# FACTORSATION

## COMMON FACTORS

$$ab + ac = a(b + c)$$

**Highest Common Factors** are used to write expressions in **fully** factorised form.

Factorise **fully**:  $4a - 2a^2$

$$= 2a(2 - a)$$

$$2a \times 2 - 2a \times a \text{ using } HCF(4a, 2a^2) = 2a$$

NOTE: the following answers are factorised but not **fully** factorised:

$$2(2a - a^2)$$

$$a(4 - 2a)$$

## DIFFERENCE OF TWO SQUARES

$$a^2 - b^2 = (a + b)(a - b)$$

Factorise **fully**:

$$(1) 4x^2 - 9$$

$$(2) 4x^2 - 36$$

$$= (2x)^2 - 3^2$$

$$= 4(x^2 - 9)$$

*common factor first*

$$= (2x + 3)(2x - 3)$$

$$= 4(x + 3)(x - 3)$$

NOTE:  $(2x + 6)(2x - 6)$  is factorised but not **fully** factorised.



## TRINOMIALS

$$ax^2 + bx + c, a = 1 \quad \text{ie. } 1x^2$$

$x^2 + bx + c = (x + ?)(x + ?)$       The missing numbers are: **a pair of factors of c**  
that **sum to b**

Factorise **fully**:

(1)  $x^2 + 5x + 6$

(2)  $x^2 - 5x + 6$

(3)  $x^2 - 5x - 6$

$$1 \times 6 = 2 \times 3 = 6$$

$$-1, -6 \text{ or } -2, -3$$

$$-1, 6 \text{ or } 1, -6 \text{ or } -2, 3 \text{ or } 2, -3$$

$$2 + 3 = 5$$

$$-2 + (-3) = -5$$

$$1 + (-6) = -5$$

use +2 and +3

use -2 and -3

use +1 and -6

$$= (x + 2)(x + 3)$$

$$= (x - 2)(x - 3)$$

$$= (x + 1)(x - 6)$$

$$ax^2 + bx + c, a \neq 1 \quad \text{ie. not } 1x^2$$

Try out the possible combinations of the factors which could be in the brackets.

Factorise  $3t^2 - 10t - 8$

$3 \times (-8) = -24$  pairs of factors 1,24 or 2,12 or 3,8 or 4,6 one factor is negative

$$\overbrace{3t^2 - 10t - 8}$$

$$-12 + 2 = -10$$

factors sum to -10

$$-12t + 2t = -10t$$

try combinations so that  $-12t$  and  $2t$  are obtained

factor pairs:  $3t \times t$  for  $3t^2$

$1 \times 8$  or  $2 \times 4$  for 8, one factor negative

$$\begin{array}{cc} 3t & +1 \\ & \swarrow \searrow \\ t & -8 \\ 1t & -24t \end{array}$$

$$\begin{array}{cc} 3t & -8 \\ & \swarrow \searrow \\ t & +1 \\ -8t & 3t \end{array}$$

$$\begin{array}{cc} 3t & +2 \\ & \swarrow \searrow \\ t & -4 \\ 2t & -12t \end{array} \quad \checkmark$$

$$\begin{array}{cc} 3t & +4 \\ & \swarrow \searrow \\ t & -2 \\ 4t & -6t \end{array}$$

$$\underline{\underline{(3t + 2)(t - 4)}}$$

# ALGEBRAIC FRACTIONS

**SIMPLIFYING:** fully factorise 'top' and 'bottom' and 'cancel' common factors

**MULTIPLY/DIVIDE:**

$$\frac{a}{b} \times \frac{c}{d} = \frac{a \times c}{b \times d}$$

$$\frac{a}{b} \div \frac{c}{d} = \frac{a}{b} \times \frac{d}{c}$$

**ADD/SUBTRACT:** a common denominator is required.

$$(1) \quad \frac{x^2 - 9}{x^2 + 2x - 3}$$

$$= \frac{(x-3)(x+3)}{(x-1)(x+3)} \quad \text{fully factorise}$$

$$= \frac{x-3}{x-1} \quad \text{cancel common factors}$$

$$(2) \quad \frac{4}{ab} \div \frac{8a}{b^2}$$

$$= \frac{4}{ab} \times \frac{b^2}{8a}$$

$$= \frac{4 \times b^2}{ab \times 8a}$$

$$= \frac{4 \times b \times b}{8 \times a \times a \times b}$$

$$= \frac{1 \times b}{2 \times a \times a}$$

$$= \frac{b}{2a^2}$$

$$(3) \quad \frac{x}{2} - \frac{x-3}{3}$$

$$= \frac{3x}{6} - \frac{2(x-3)}{6}$$

$$= \frac{3x - 2(x-3)}{6}$$

$$= \frac{3x - 2x + 6}{6} \quad \text{notice sign change}$$

$$= \frac{x+6}{6}$$

$$(4) \quad \frac{1}{x} + \frac{3}{x(x-3)}$$

$$= \frac{1(x-3)}{x(x-3)} + \frac{3}{x(x-3)}$$

$$= \frac{x-3+3}{x(x-3)}$$

$$= \frac{x}{x(x-3)} \quad \text{can simplify}$$

$$= \frac{1}{x-3}$$

## CHAPTER 12: EQUATIONS and INEQUALITIES

Simplify by following the rules:

### addition and subtraction

$$\begin{array}{l} x + a = b \\ x = b - a \end{array} \qquad \begin{array}{l} x - a = b \\ x = b + a \end{array}$$

### multiplication and division

$$\begin{array}{l} ax = b \\ x = \frac{b}{a} \end{array} \qquad \begin{array}{l} \frac{x}{a} = b \\ x = ab \end{array}$$

(1) Solve:  $5x - 4 = 2x - 19$

$$\begin{array}{l} 3x - 4 = -19 \\ 3x = -15 \\ x = -5 \end{array} \qquad \begin{array}{l} \textit{subtracted } 2x \textit{ from each side} \\ \textit{added } 4 \textit{ to each side} \\ \textit{divided each side by } 3 \end{array}$$

### WITH BRACKETS remove first and simplify

(2) Solve:  $(4x + 3)(x - 2) = (2x - 3)^2$

$$\begin{array}{l} 4x^2 - 5x - 6 = 4x^2 - 12x + 9 \\ -5x - 6 = -12x + 9 \\ 7x - 6 = +9 \\ 7x = 15 \\ x = \frac{15}{7} \end{array} \qquad \begin{array}{l} \textit{removed brackets, fully simplifying} \\ \textit{subtracted } 4x^2 \textit{ from each side} \\ \textit{added } 12x \textit{ to each side} \\ \textit{added } 6 \textit{ to each side} \\ \textit{divided each side by } 7 \end{array}$$

### WITH FRACTIONS remove first, multiplying by the LCM of the denominators

(3) Solve  $\frac{1}{2}(x + 3) + \frac{1}{3}x = 1$

$$\begin{array}{l} \frac{3}{6}(x + 3) + \frac{2}{6}x = \frac{6}{6} \\ 3(x + 3) + 2x = 6 \\ 3x + 9 + 2x = 6 \\ 5x = -3 \\ x = -\frac{3}{5} \end{array} \qquad \begin{array}{l} \textit{write with common denominators} \\ \textit{both sides } \times 6 \textit{ to remove fractions} \end{array}$$

# INEQUALITIES

Follow the rules for equations, except:

**multiply or divide** by a **negative** number, reverse the direction of the inequality sign

$$-ax > b \qquad \frac{x}{-a} > b$$

$$x < \frac{b}{-a} \qquad x < -ab$$

$$(1) \quad 8 + 3x > 2$$

$$+3x > -6$$

$$x > \frac{-6}{+3} \quad \text{divided each side by } +3 \\ \text{notice sign unchanged}$$

$$x > -2$$

$$(2) \quad 8 - 3x > 2$$

$$-3x > -6 \quad \text{subtracted 8 from each side}$$

$$x < \frac{-6}{-3} \quad \text{divided each side by } -3 \\ \text{notice sign reversed}$$

$$x < 2 \quad \text{simplified}$$

## RESTRICTIONS ON SOLUTIONS

$$(1) \quad x \leq \frac{5}{2} \quad \text{where } x \text{ is a whole number}$$

$$x = 0, 1, 2$$

$$(2) \quad -2 \leq x < 2 \quad \text{where } x \text{ is an integer}$$

$$x = -2, -1, 0, 1$$

# TRANSPOSING FORMULAE (CHANGE OF SUBJECT)

Follow the rules for equations to isolate the **target letter**.

## addition and subtraction

$$\begin{array}{l} x + a = b \\ x = b - a \end{array} \qquad \begin{array}{l} x - a = b \\ x = b + a \end{array}$$

## multiplication and division

$$\begin{array}{l} ax = b \\ x = \frac{b}{a} \end{array} \qquad \begin{array}{l} \frac{x}{a} = b \\ x = ab \end{array}$$

## powers and roots

$$\begin{array}{l} x^2 = a \\ x = \sqrt{a} \end{array} \qquad \begin{array}{l} \sqrt{x} = a \\ x = a^2 \end{array}$$

$F = 3r^2 + p$     Change the subject of the formula to r.

$$\begin{array}{ccccccc} r & \xrightarrow{\text{square}} & r^2 & \xrightarrow{\times 3} & 3r^2 & \xrightarrow{+p} & F \\ \sqrt{\frac{F-p}{3}} & \xleftarrow{\sqrt{\quad}} & \frac{F-p}{3} & \xleftarrow{\div 3} & F-p & \xleftarrow{-p} & F \end{array}$$

inverse operations in reverse order

$$F = 3r^2 + p$$

$$F - p = 3r^2 \qquad \text{subtract } p \text{ from each side}$$

$$\frac{F-p}{3} = r^2 \qquad \text{divide each side by 3}$$

$$\sqrt{\frac{F-p}{3}} = r \qquad \text{square root both sides}$$

$$r = \sqrt{\frac{F-p}{3}} \qquad \text{subject of formula now } r$$

# CHAPTER 13: STRAIGHT LINE

**GRADIENT** The slope of a line is given by the ratio:

$$m = \frac{\text{vertical change}}{\text{horizontal change}}$$

Using coordinates, the **gradient formula** is

$$m_{AB} = \frac{y_B - y_A}{x_B - x_A}$$

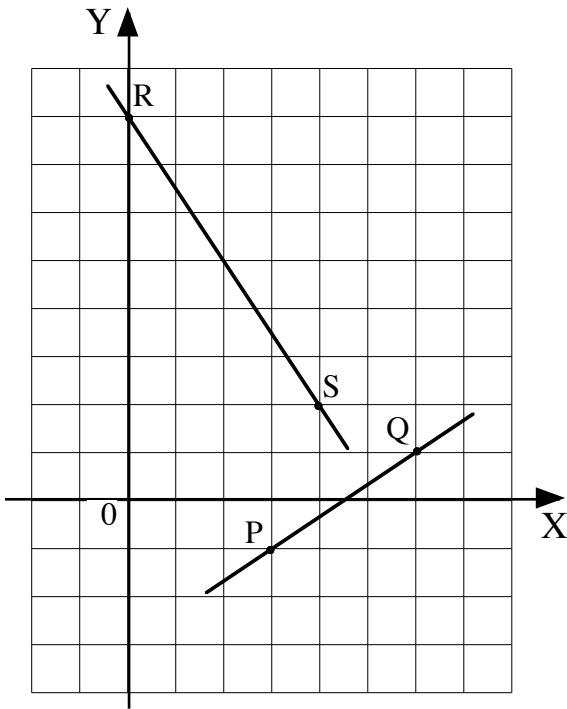

$$R(0,8) \quad , \quad S(4,2)$$

$$m_{RS} = \frac{y_S - y_R}{x_S - x_R} = \frac{2 - 8}{4 - 0} = \frac{-6}{4} = -\frac{3}{2}$$

$$P(3,-1) \quad , \quad Q(6,1)$$

$$m_{PQ} = \frac{y_Q - y_P}{x_Q - x_P} = \frac{1 - (-1)}{6 - 3} = \frac{2}{3}$$

note: same result for  $\frac{-1 - 1}{3 - 6} = \frac{-2}{-3} = \frac{2}{3}$

## EQUATION OF A STRAIGHT LINE

gradient  $m$  , y-intercept  $C$  units ie. meets the y-axis at  $(0,C)$

$$y = mx + C$$

gradient  $m$  , through the point  $(a,b)$

$$y - b = m(x - a)$$

equation of line RS:

$$m_{RS} = -\frac{3}{2} \quad y = mx + C$$

$$R(0,8) \quad C = 8 \quad y = -\frac{3}{2}x + 8$$

equation of line PQ:

$$m_{PQ} = \frac{2}{3} \quad y - b = m(x - a)$$

$$\begin{matrix} a & b \\ Q(6, 1) \end{matrix} \quad y - 1 = \frac{2}{3}(x - 6)$$

or use point P

$$3y - 3 = 2(x - 6)$$

$$3y - 3 = 2x - 12$$

$$3y = 2x - 9$$

Rearrange the equation to  $y = mx + C$  for the gradient and y-intercept.

$$3x + 2y - 16 = 0$$

$$2y = -3x + 16 \quad \text{isolate } y \text{ - term}$$

$$y = -\frac{3}{2}x + 8 \quad \text{obtain } 1y =$$

$$y = mx + C \quad \text{compare to the general equation}$$

$$m = -\frac{3}{2}, \quad C = 8 \quad \text{meets the } Y \text{ - axis at } (0,8)$$

**RATE OF CHANGE** The gradient is the rate of change.

**distance/time graphs:** the gradient is the speed.

**speed/time graphs:** the gradient is the acceleration.

The steeper the graph, the greater the rate of change.

A positive gradient is an increase, a negative gradient is a decrease.

Gradient zero (horizontal line), no change.

RENTAL TAXIS requires a £4 payment plus a charge of 50p per mile.

CITY TAXIS charges £1.50 per mile.

Advise on the better buy.

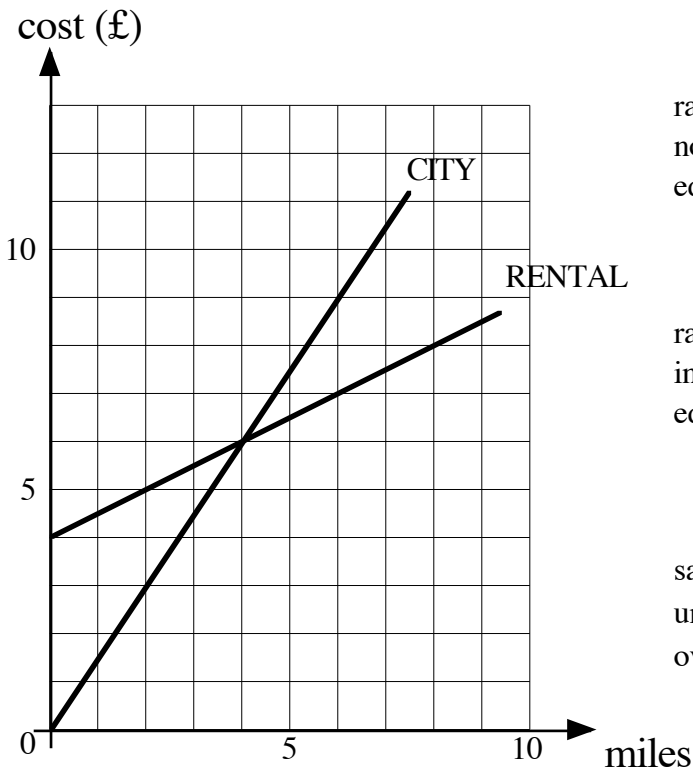

rate of change £1.50 per mile ,  $m = 1.5$   
 no initial charge ,  $C = 0$   
 equation  $y = 1.5x$

rate of change £0.50 per mile ,  $m = 0.5$   
 initial charge £4 ,  $C = 4$   
 equation  $y = 0.5x + 4$

same cost for 4 miles, but  
 under 4 miles CITY cheaper  
 over 4 miles RENTAL cheaper

## SCATTER DIAGRAM: LINE OF BEST FIT

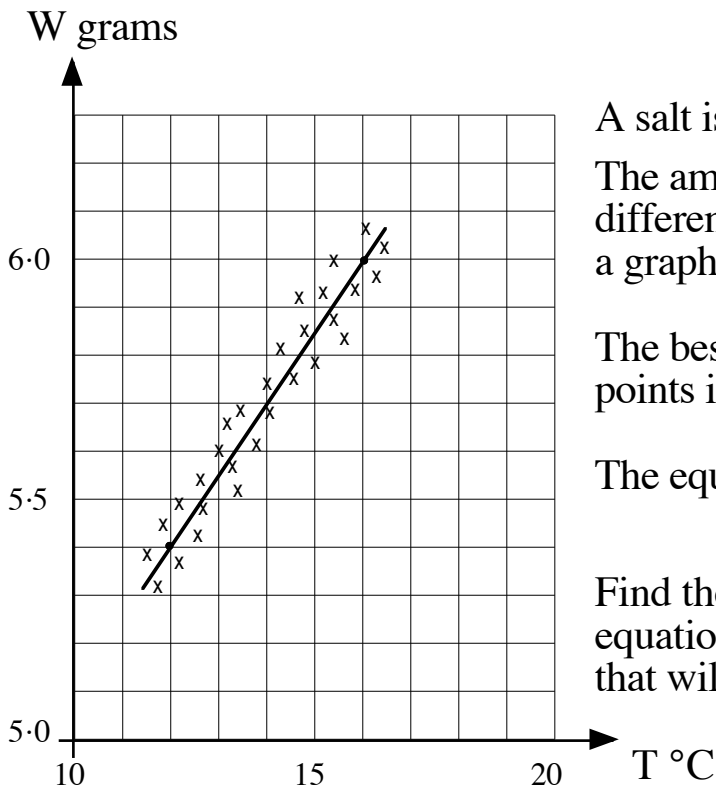

A salt is dissolved in a litre of solvent. The amount of salt that dissolves at different temperatures is recorded and a graph plotted.

The best-fitting straight line through the points is drawn.

The equation of the graph is of the form  

$$W = mT + C.$$

Find the equation of the line and use the equation to calculate the mass of salt that will dissolve at 30 °C.

using two well-separated points on the line (16 , 6.0) (12 , 5.4)

$$m = \frac{6.0 - 5.4}{16 - 12} = \frac{0.6}{4} = 0.15$$

substituting for one point on the line  $\begin{matrix} a & b \\ (16 , 6.0) \end{matrix}$

$$y - b = m(x - a)$$

$$y - 6.0 = 0.15(x - 16)$$

$$y - 6.0 = 0.15x - 2.4$$

$$y = 0.15x + 3.6$$

$$\underline{\underline{W = 0.15T + 3.6}}$$

$$T = 30$$

$$W = 0.15 \times 30 + 3.6$$

$$= 4.5 + 3.6$$

$$= 8.1$$

$$\underline{\underline{8.1 \text{ grams}}}$$



# CHAPTER 14: SIMULTANEOUS EQUATIONS

The equation of a line is a rule connecting the x and y coordinates of any point on the line.

For example, 
$$\begin{array}{r} x \quad y \\ (-2, 12) \end{array} \quad \begin{array}{l} y + 2x = 8 \\ 12 + 2 \times (-2) = 8 \end{array}$$

To sketch a line, find the points where the line meets the axes.

## SOLVE SIMULTANEOUS EQUATIONS: GRAPHICAL METHOD

Sketch the two lines and the point of intersection is the solution.

Solve **graphically** the system of equations: 
$$\begin{array}{l} y + 2x = 8 \\ y - x = 2 \end{array}$$

$$\begin{array}{l} y + 2x = 8 \quad (1) \\ y + 2 \times 0 = 8 \quad \text{substituted for } x = 0 \\ y = 8 \quad \text{plot } (0, 8) \end{array}$$

$$\begin{array}{l} y - x = 2 \quad (2) \\ y - 0 = 2 \quad \text{substituted for } x = 0 \\ y = 2 \quad \text{plot } (0, 2) \end{array}$$

$$\begin{array}{l} y + 2x = 8 \quad (1) \\ 0 + 2x = 8 \quad \text{substituted for } y = 0 \\ x = 4 \quad \text{plot } (4, 0) \end{array}$$

$$\begin{array}{l} y - x = 2 \quad (2) \\ 0 - x = 2 \quad \text{substituted for } y = 0 \\ x = -2 \quad \text{plot } (-2, 0) \end{array}$$

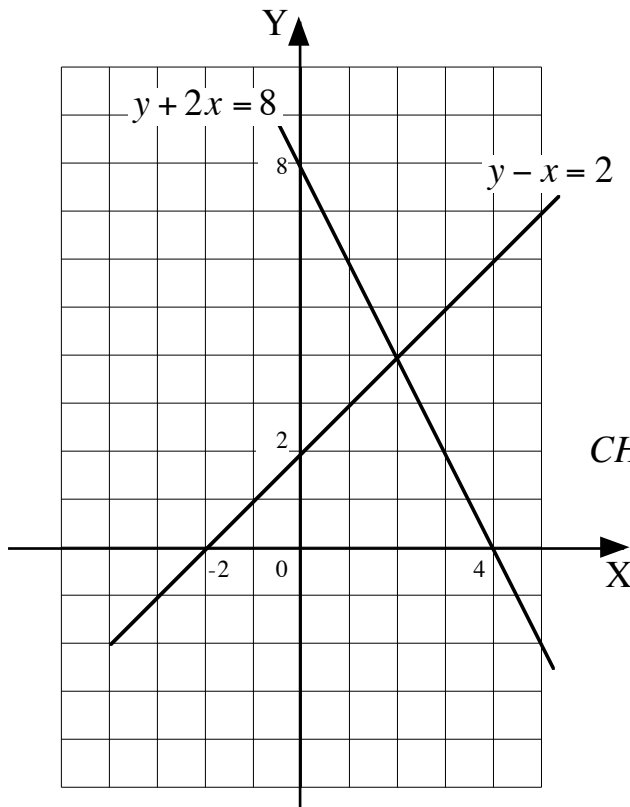

point of intersection (2,4)

**SOLUTION:**  $x = 2$  and  $y = 4$

**CHECK:**  $x = 2$  and  $y = 4$   
substituted in both equations

$$\begin{array}{l} y + 2x = 8 \quad (1) \\ 4 + 2 \times 2 = 8 \\ 8 = 8 \end{array} \quad \begin{array}{l} y - x = 2 \quad (2) \\ 4 - 2 = 2 \\ 2 = 2 \end{array}$$

## SOLVE SIMULTANEOUS EQUATIONS: SUBSTITUTION METHOD

Rearrange one equation to  $y =$  and substitute for  $y$  in the other equations  
( or  $x =$  )

Solve **algebraically** the system of equations:  $y + 2x = 8$

$$3y - x = 10$$

$$y + 2x = 8 \quad (1)$$

$$y = 8 - 2x$$

*can choose to rearrange to  $y =$  or  $x =$*

*choosing  $y =$  avoids fractions as  $x = 4 - \frac{1}{2}y$*

$$3y - x = 10 \quad (2)$$

$$3(8 - 2x) - x = 10$$

$$24 - 6x - x = 10$$

$$-7x = -14$$

$$x = 2$$

*replace  $y$  by  $8 - 2x$*

*solve*

$$y = 8 - 2x \quad (1)$$

$$= 8 - 2 \times 2$$

$$y = 4$$

*can choose either equation (1) or (2)*

*substituted for  $x = 2$*

**SOLUTION:**  $x = 2$  and  $y = 4$

**CHECK:**

$$3y - x = 10 \quad (2)$$

$$3 \times 4 - 2 = 10$$

$$10 = 10$$

*using the other equation*

*substituted for  $x = 2$  and  $y = 4$*

## SOLVE SIMULTANEOUS EQUATIONS: ELIMINATION METHOD

Can add or subtract multiples of the equations to eliminate either the  $x$  or  $y$  term.

Solve **algebraically** the system of equations:  $4x + 3y = 5$   
 $5x - 2y = 12$

$$\begin{array}{lll} 4x + 3y = 5 & (1) \times 2 & \text{can choose to eliminate } x \text{ or } y \text{ term} \\ 5x - 2y = 12 & (2) \times 3 & \text{choosing } y \text{ term, LCM } (3y, 2y) = 6y \\ \\ 8x + 6y = 10 & (3) & \text{multiplied each term of (1) by 2 for } +6y \\ 15x - 6y = 36 & (4) & \text{multiplied each term of (2) by 3 for } -6y \\ \\ 23x & = 46 & (3) + (4) \quad \text{added equations, adding "like" terms} \\ x = 2 & & +6y \text{ and } -6y \text{ added to 0 (ie eliminate)} \end{array}$$

$$\begin{array}{ll} 4x + 3y = 5 & (1) \\ 4 \times 2 + 3y = 5 & \text{can choose either equation (1) or (2)} \\ 8 + 3y = 5 & \text{substituted for } x = 2 \\ 3y = -3 & \\ y = -1 & \end{array}$$

**SOLUTION:**  $x = 2$  and  $y = -1$

**CHECK:**

$$\begin{array}{ll} 5x - 2y = 12 & (2) \\ 5 \times 2 - 2 \times (-1) = 12 & \text{using the other equation} \\ 10 - (-2) = 12 & \text{substituted for } x = 2 \text{ and } y = -1 \\ 12 = 12 & \end{array}$$

# CHAPTER 15: QUADRATIC EQUATIONS

A function pairs one number with another, its IMAGE. It can be defined by a formula.

## QUADRATIC FUNCTIONS

$f(x) = ax^2 + bx + c$ ,  $a \neq 0$ , where  $a$ ,  $b$  and  $c$  are constants.

$$f(x) = x^2 - 2x - 3$$

$f(-2) = (-2)^2 - 2 \times (-2) - 3 = 4 + 4 - 3 = 5$ , the image of -2 is 5.

$x$	-2	-1	0	1	2	3	4
$f(x)$	5	0	-3	-4	-3	0	5
points	(-2,5)	(-1,0)	(0,-3)	(1,-4)	(2,-3)	(3,0)	(4,5)

If all possible values of  $x$  are considered, a graph will show the images (the RANGE). The graph is a symmetrical curve called a PARABOLA.

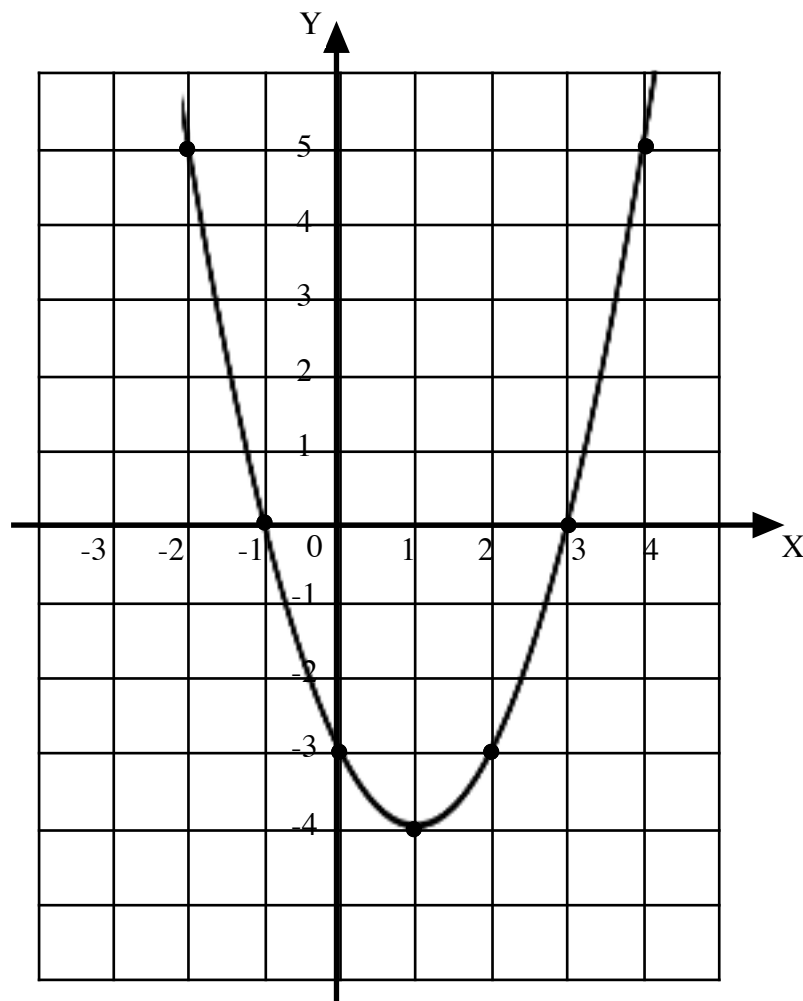

The graph meets the x-axis where  $x^2 - 2x - 3 = 0$ .

The **zeros** of the graph are -1 and 3 which are the **roots** of the equation.

# QUADRATIC EQUATIONS

An equation of the form  $ax^2 + bx + c = 0$ ,  $a \neq 0$ , where  $a$ ,  $b$  and  $c$  are constants.

The values of  $x$  that satisfy the equation are the **roots** of the equation.

The quadratic formula can be used to solve the equation.

## QUADRATIC FORMULA

$$x = \frac{-b \pm \sqrt{b^2 - 4ac}}{2a}, a \neq 0$$

Find the **roots** of the equation  $3x^2 - 5x - 1 = 0$ , correct to two decimal places.

$$3x^2 - 5x - 1 = 0$$

$$ax^2 + bx + c = 0$$

$$x = \frac{-b \pm \sqrt{b^2 - 4ac}}{2a}$$

$$a = 3, b = -5, c = -1$$

$$x = \frac{5 \pm \sqrt{37}}{6}$$

$$b^2 - 4ac = (-5)^2 - 4 \times 3 \times (-1) = 37$$

$$-b = -(-5) = +5$$

$$2a = 2 \times 3 = 6$$

$$= \frac{5 - \sqrt{37}}{6} \quad \text{or} \quad \frac{5 + \sqrt{37}}{6}$$

$$= \frac{-1.0827\dots}{6} \quad \text{or} \quad \frac{11.0827\dots}{6}$$

$$x = -0.1804\dots \quad \text{or} \quad 1.8471\dots$$

roots are -0.18 and 1.85

## DISCRIMINANT

$b^2 - 4ac$  gives the nature of the roots

(i)  $b^2 - 4ac < 0$  NO REAL ROOTS  
ie. negative

(ii)  $b^2 - 4ac = 0$  ONE REAL ROOT (repeated)  
(two EQUAL roots)

(iii)  $b^2 - 4ac > 0$  TWO REAL ROOTS  
(and DISTINCT)

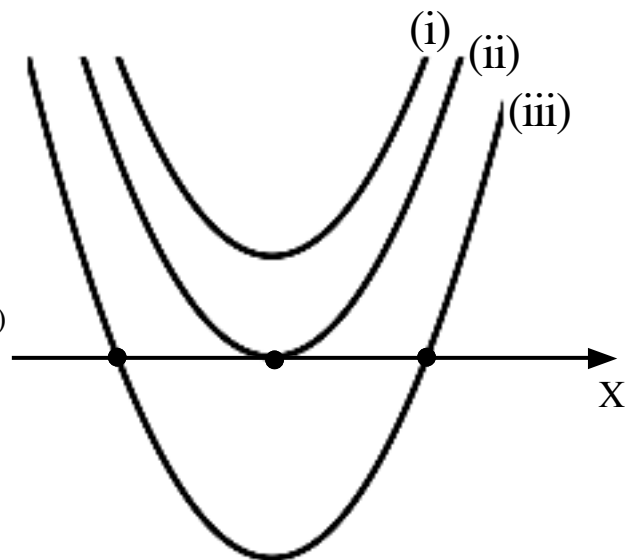

Find  $k$  so that  $2x^2 - 4x - k = 0$  has **real** roots.

$$2x^2 - 4x - k = 0$$

$$ax^2 + bx + c = 0$$

for real roots,  $b^2 - 4ac \geq 0$

$$16 + 8k \geq 0$$

$$a = 2, \quad b = -4, \quad c = -k$$

$$8k \geq -16$$

$$b^2 - 4ac = (-4)^2 - 4 \times 2 \times (-k)$$

$$= 16 + 8k$$

$$k \geq -2$$

## FACTORISATION

RATIONAL ROOTS  
(non-surds)

$b^2 - 4ac =$  a square number ie. 0, 1, 4, 9, 16, ....  
the quadratic can be factorised to solve the equation.

IRRATIONAL ROOTS  
(surds)

$b^2 - 4ac \neq$  a square number  
solve the equation by formula.

Solve:

$$(1) \quad 4n - 2n^2 = 0$$

$$(2) \quad 2t^2 + t - 6 = 0$$

$$2n(2 - n) = 0$$

$$(2t - 3)(t + 2) = 0$$

$$2n = 0 \quad \text{or} \quad 2 - n = 0$$

$$2t - 3 = 0 \quad \text{or} \quad t + 2 = 0$$

$$\underline{\underline{n = 0 \quad \text{or} \quad n = 2}}$$

$$2t = 3$$

$$\underline{\underline{t = \frac{3}{2} \quad \text{or} \quad t = -2}}$$

The equation may need to be rearranged:

$$(3) \quad (w + 1)^2 = 2(w + 5)$$

$$(4) \quad x + 2 = \frac{15}{x}, \quad x \neq 0$$

$$w^2 + 2w + 1 = 2w + 10$$

$$x(x + 2) = 15$$

$$w^2 - 9 = 0$$

$$x^2 + 2x = 15$$

$$(w + 3)(w - 3) = 0$$

$$x^2 + 2x - 15 = 0$$

$$w + 3 = 0 \quad \text{or} \quad w - 3 = 0$$

$$(x + 5)(x - 3) = 0$$

$$\underline{\underline{w = -3 \quad \text{or} \quad w = 3}}$$

$$x + 5 = 0 \quad \text{or} \quad x - 3 = 0$$

$$\underline{\underline{x = -5 \quad \text{or} \quad x = 3}}$$

## GRAPHS

A sketch of the graph of a quadratic function should show where the parabola meets the axes and the maximum or minimum turning point.

Sketch the graph  $y = x^2 - 2x - 3$ .

(i) meets the Y-axis where  $x = 0$

$$y = 0^2 - 2 \times 0 - 3 = -3 \text{ point } (0, -3)$$

(ii) meets the X-axis where  $y = 0$

$$x^2 - 2x - 3 = 0$$

$$(x + 1)(x - 3) = 0$$

$$x = -1 \text{ or } x = 3$$

points  $(-1, 0)$  and  $(3, 0)$

(iii) axis of symmetry

vertical line half-way between the zeros

$$x = \frac{-1 + 3}{2} = \frac{2}{2} = 1, \text{ equation } x = 1.$$

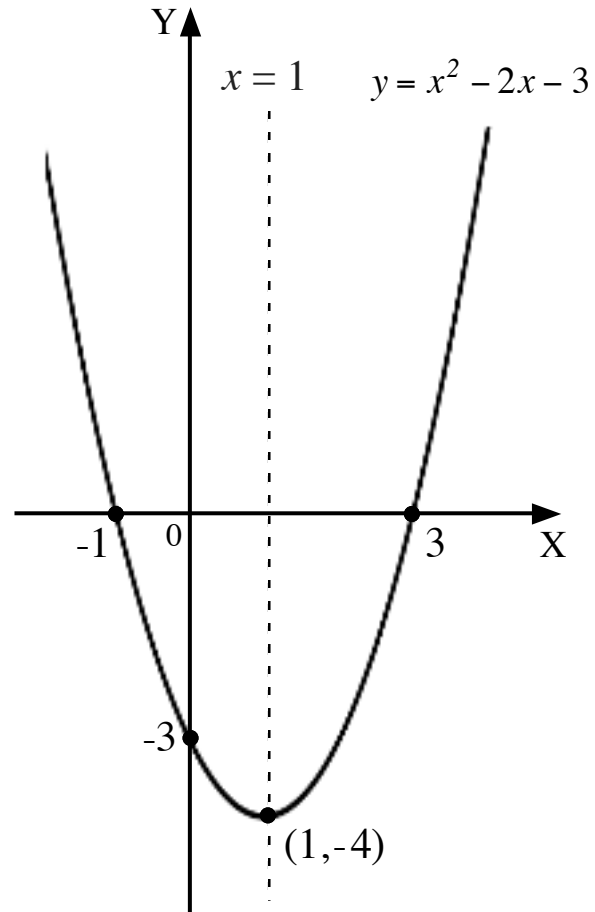

(iv) turning point

lies on the axis of symmetry  $x = 1$

$$y = 1^2 - 2 \times 1 - 3 = -4 \text{ point } (1, -4)$$

Note: (1) from the graph,  $(1, -4)$  is a **minimum turning point**.

(2) the **minimum value** of the function is  $-4$ .

## APPLICATIONS

Problems involving maxima or minima which can be modelled by a quadratic equation.

A sheet of metal 40 cm. wide is folded  $x$  cm from each end to form a gutter. To maximise water flow the rectangular cross-section should be as large as possible.

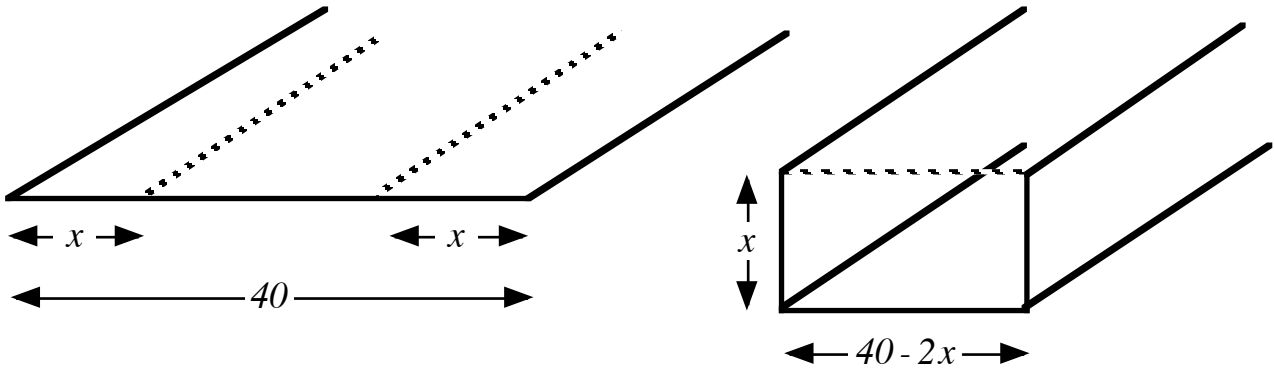

Find the maximum cross-sectional area possible.

$$\begin{aligned}
 A &= lb \\
 &= x(40 - 2x) \quad \text{sketch the graph } A = 40x - 2x^2 \\
 &= 40x - 2x^2
 \end{aligned}$$

Zeros:

$$\begin{aligned}
 40x - 2x^2 &= 0 \\
 2x(20 - x) &= 0 \\
 2x = 0 \quad \text{or} \quad 20 - x = 0 \\
 x = 0 \quad \text{or} \quad x = 20
 \end{aligned}$$

Turning Point:

$$\begin{aligned}
 (0 + 20) \div 2 &= 10 \\
 \text{axis of symmetry } x &= 10
 \end{aligned}$$

$$\begin{aligned}
 y &= 40x - 2x^2 \\
 y &= 40 \times 10 - 2 \times 10^2 = 200
 \end{aligned}$$

maximum turning point  $(10, 200)$

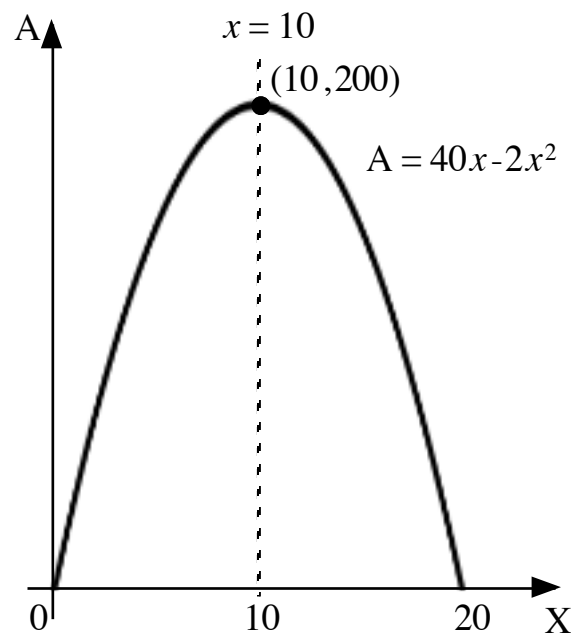

Maximum area 200 square centimetres.



## EQUATION OF A GRAPH

$$y = k(x - a)(x - b)$$

$a$  and  $b$  are the zeros of the graph

$k$  is a constant.

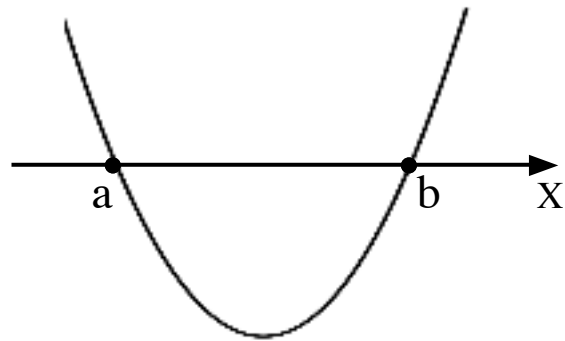

Write the equation of the graph.

$$y = k(x - a)(x - b)$$

zeros  $-1$  and  $3$

$$y = k(x + 1)(x - 3)$$

for  $\begin{matrix} x & y \\ (0, & -6) \end{matrix}$ ,  $-6 = k(0 + 1)(0 - 3)$

$$-6 = k \times 1 \times (-3)$$

$$-6 = -3k$$

$$k = 2$$

$$y = 2(x + 1)(x - 3)$$

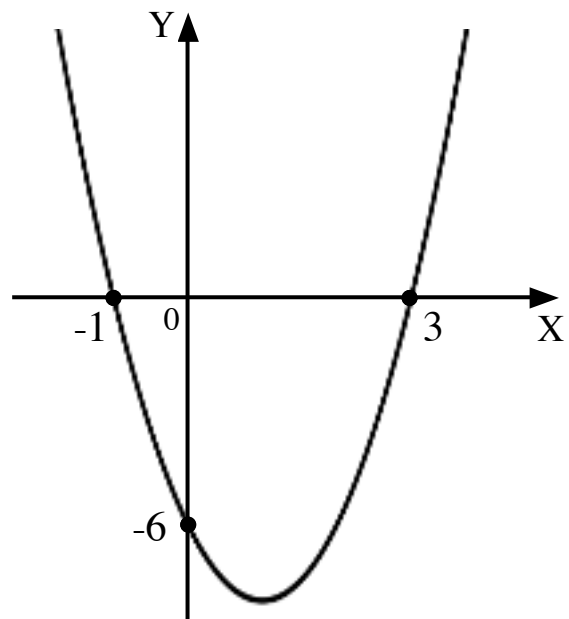

Write the equation of the graph.

$$y = kx^2$$

for  $\begin{matrix} x & y \\ (-3, & 18) \end{matrix}$ ,  $18 = k \times (-3)^2$

$$18 = 9k$$

$$k = 2$$

$$y = 2x^2$$

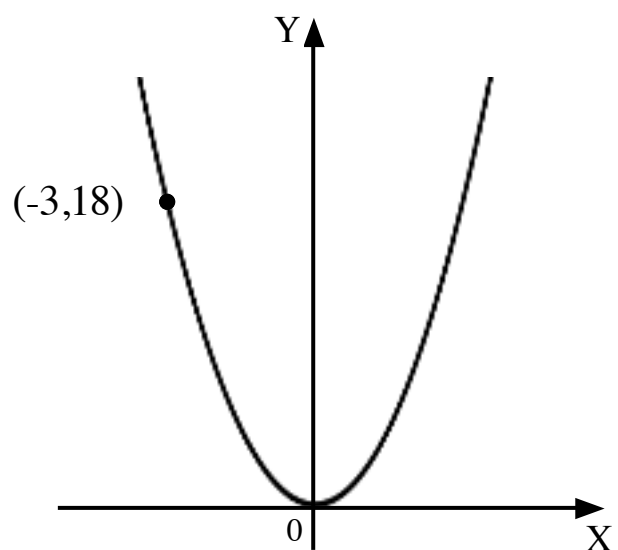

**COMPLETED SQUARE:**

Quadratic functions written in the form  $y = \pm 1(x - a)^2 + b$ ,  $a$  and  $b$  are constants.

axis of symmetry  $x = a$

turning point  $(a, b)$ , minimum for  $+1$ , maximum for  $-1$

$y = x^2 - 8x + 21$  can be written as  $y = (x - 4)^2 + 5$

*meets the y-axis where  $x = 0$*

$y = (0 - 4)^2 + 5 = 16 + 5 = 21$

*point  $(0, 21)$*

*turning point:  $y = +1(x - 4)^2 + 5$*

*minimum turning point  $(4, 5)$*

*axis of symmetry  $x = 4$*

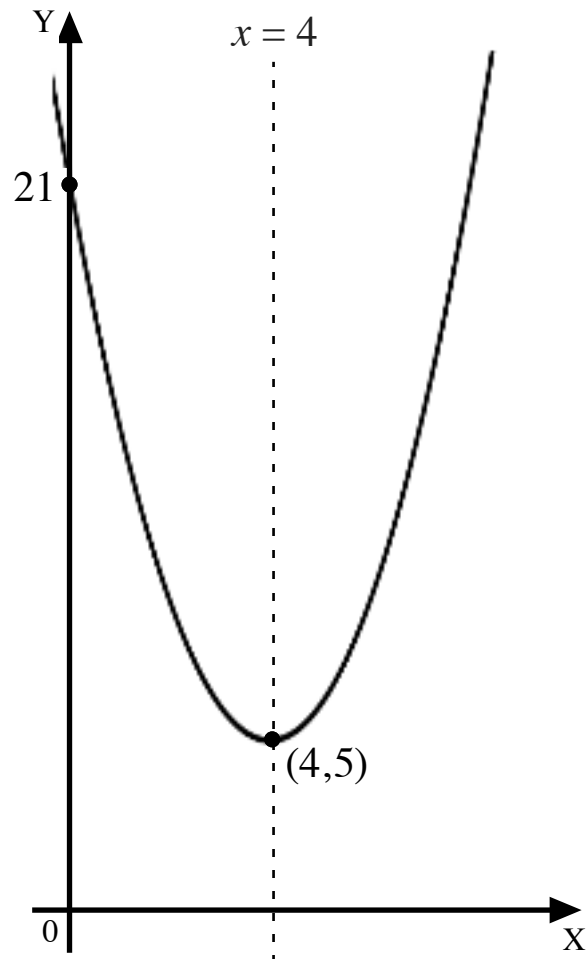

**COMPLETING THE SQUARE:**

$x^2 - 8x + 21$

$x^2 - 8x$                        $+ 21$       *coefficient of  $x$ ,  $-8$ , is halved and squared,  $(-4)^2$  to 16*

$= x^2 - 8x + 16 - 16 + 21$       *add and subtract 16*

$= (x - 4)^2 - 16 + 21$       *complete square around trinomial*

$= (x - 4)^2 + 5$

# CHAPTER 16: TRIGONOMETRY: RIGHT-ANGLED TRIANGLES

## SOH-CAH-TOA

The sides of a right-angled triangle are labelled:

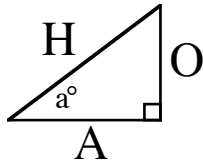

**Opposite:** opposite the angle  $a^\circ$ .

**Adjacent:** next to the angle  $a^\circ$ .

**Hypotenuse:** opposite the right angle.

The ratios of sides  $\frac{O}{H}$ ,  $\frac{A}{H}$  and  $\frac{O}{A}$  have values which depend on the size of angle  $a^\circ$ .

These are called the sine, cosine and tangents of  $a^\circ$ , written  $\sin a^\circ$ ,  $\cos a^\circ$  and  $\tan a^\circ$ .

For example,

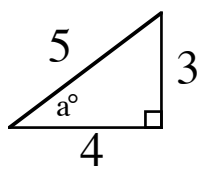

$$S = \frac{O}{H} \qquad C = \frac{A}{H} \qquad T = \frac{O}{A}$$
$$\sin a^\circ = \frac{3}{5} \qquad \cos a^\circ = \frac{4}{5} \qquad \tan a^\circ = \frac{3}{4}$$

The trig. function acts on an angle to produce the value of the ratio.

The inverse trig. function acts on the value of a ratio to produce the angle.

For example,

$$\sin 30^\circ = 0.5$$

$$\sin^{-1} 0.5 = 30^\circ$$

## ACCURACY

Rounding the angle or the value in a calculation can result in significant errors.

For example,

$$100 \times \tan 69.5^\circ = 267.462... \approx 267$$

$$\tan^{-1} 2.747 = 69.996... \approx 70.0$$

$$100 \times \tan 70^\circ = 274.747... \approx 275$$

$$\tan^{-1} 2.7 = 69.676... \approx 69.7$$

## FINDING AN UNKNOWN SIDE

(1) Find  $x$ .

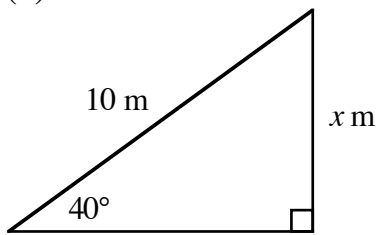

rearrange for  $x$

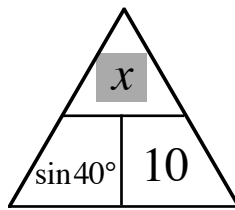

$$\sin 40^\circ = \frac{x}{10}$$

$$x = 10 \times \sin 40^\circ \quad \text{ensure calculator set to **DEGREES**}$$

$$= 6.427\dots$$

$$x = 6.4$$

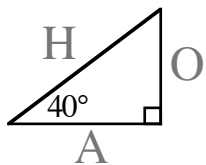

know H, find O  
 $\downarrow\downarrow \quad \downarrow\downarrow$   
SOH-CAH-TOA

(2) Find  $y$ .

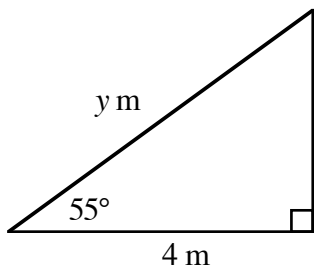

rearrange for  $y$

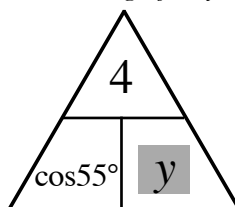

$$\cos 55^\circ = \frac{4}{y}$$

$$y = \frac{4}{\cos 55^\circ}$$

$4 \div \cos 55^\circ$ ,  
calculator set to DEGREES

$$= 6.973\dots$$

$$y = 7.0$$

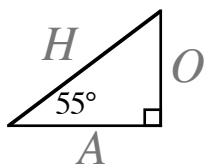

know A, find H  
 $\downarrow \quad \downarrow\downarrow \quad \downarrow$   
SOH-CAH-TOA

## FINDING AN UNKNOWN ANGLE

(3) Find  $x$ .

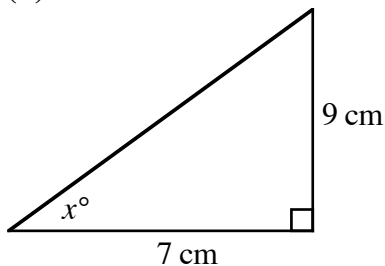

$$\tan x^\circ = \frac{9}{7}$$

$$x = \tan^{-1}\left(\frac{9}{7}\right)$$

use brackets for  $(9 \div 7)$ ,  
calculator set to DEGREES

$$= 52.125\dots$$

$$x = 52.1$$

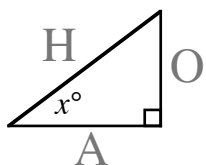

know O, know A  
 $\downarrow \quad \downarrow \quad \downarrow\downarrow$   
SOH-CAH-TOA

# CHAPTER 17: TRIGONOMETRY: GRAPHS & EQUATIONS

The cosine graph is the sine graph shifted  $90^\circ$  to the left.

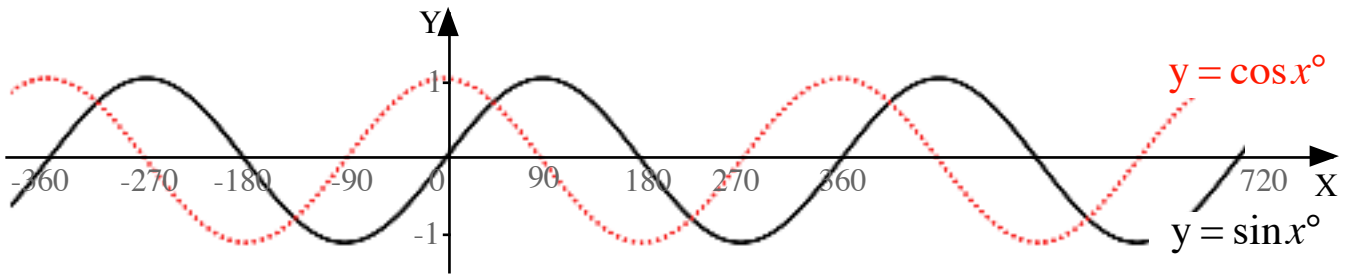

The graphs have a PERIOD of  $360^\circ$  (repeat every  $360^\circ$ ).

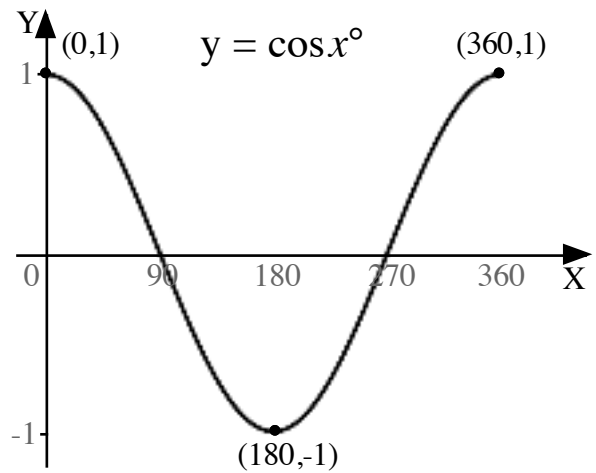
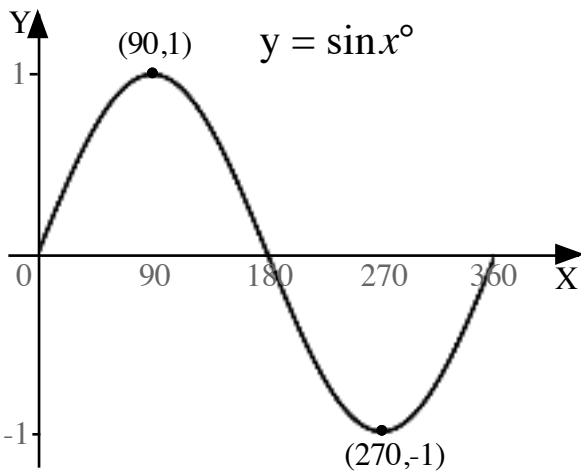

Turning points:  
maximum  $(90,1)$  , minimum  $(270,-1)$

maximum  $(0,1)$  , minimum  $(180,-1)$

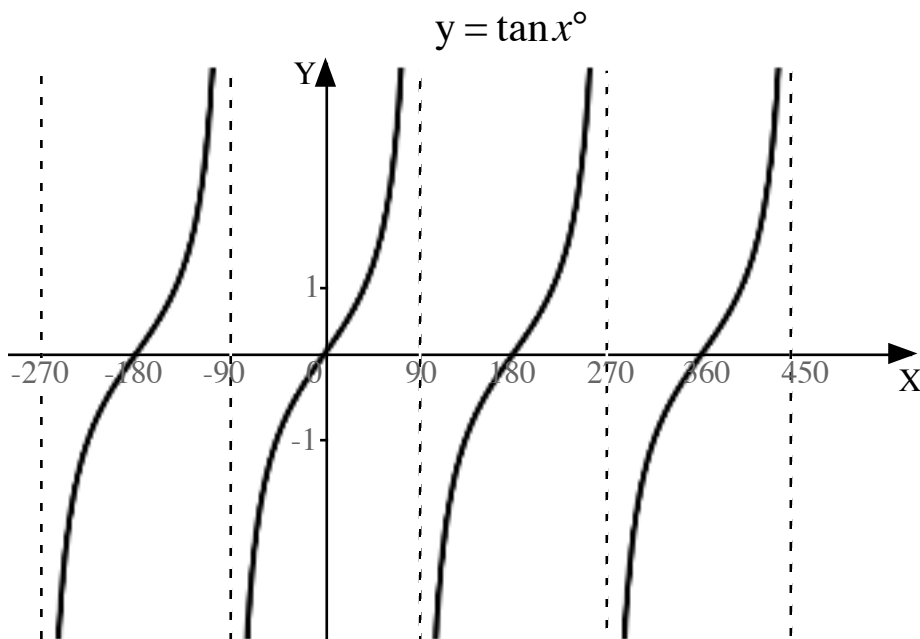

The tangent graph has a PERIOD of  $180^\circ$ .

**TRANSFORMATIONS** Same rules for  $y = \sin x^\circ$  and  $y = \cos x^\circ$ .

**Y-STRETCH**  $y = n \sin x^\circ$        $y$ -coordinates multiplied by  $n$ .  
amplitude  $n$  units  
maximum value  $+n$ , minimum value  $-n$

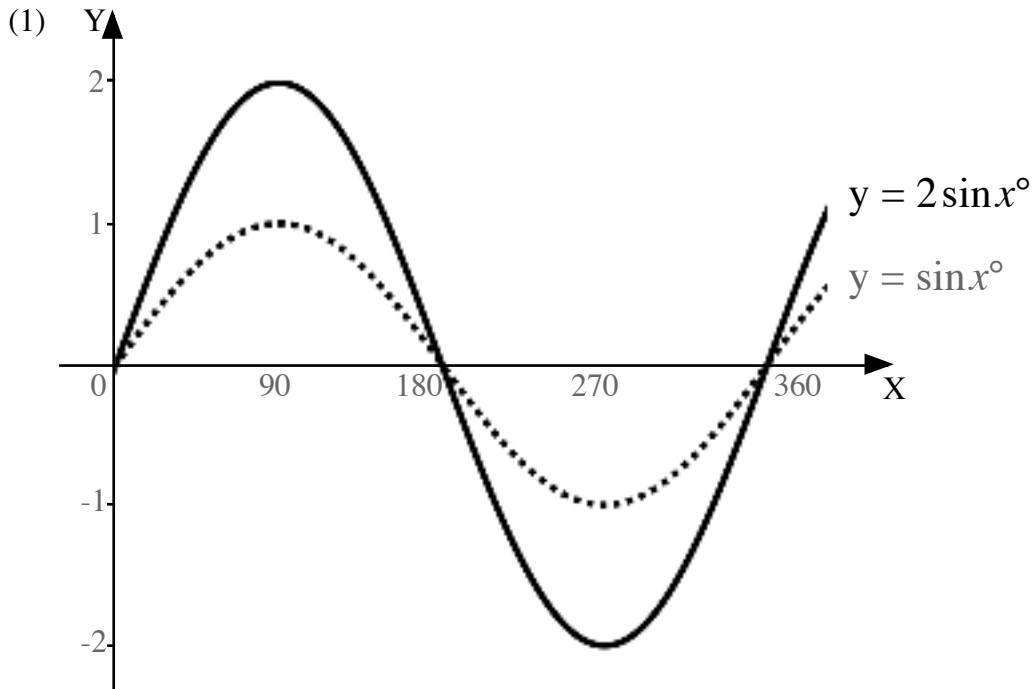

**X-STRETCH**  $y = \sin nx^\circ$        $x$ -coordinates divided by  $n$ .  
period  $360^\circ \div n$ . There are  $n$  cycles in  $360^\circ$ .

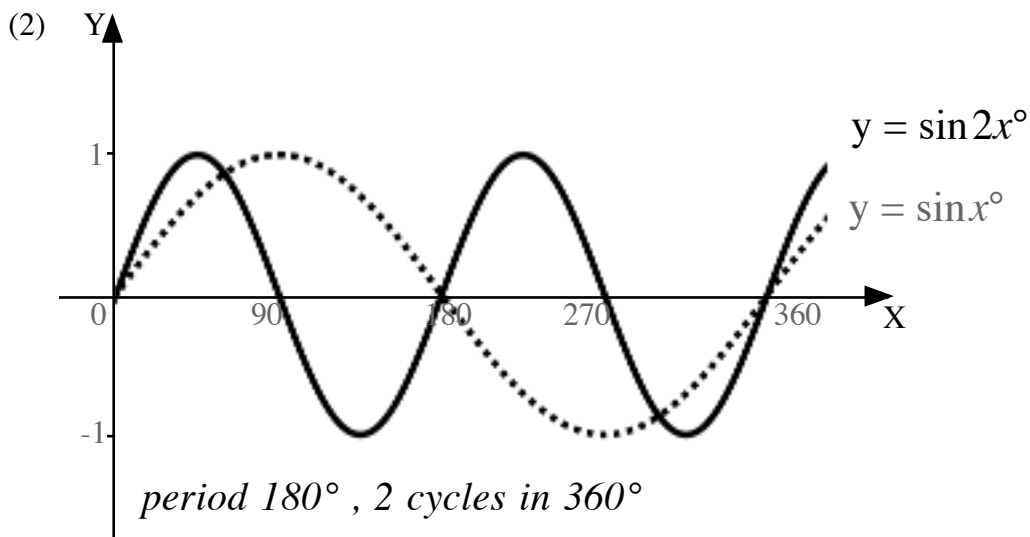

Y-SHIFT

$$y = \sin x^\circ + n$$

add **n** units to y-coordinates  
graph shifted **n** units vertically.

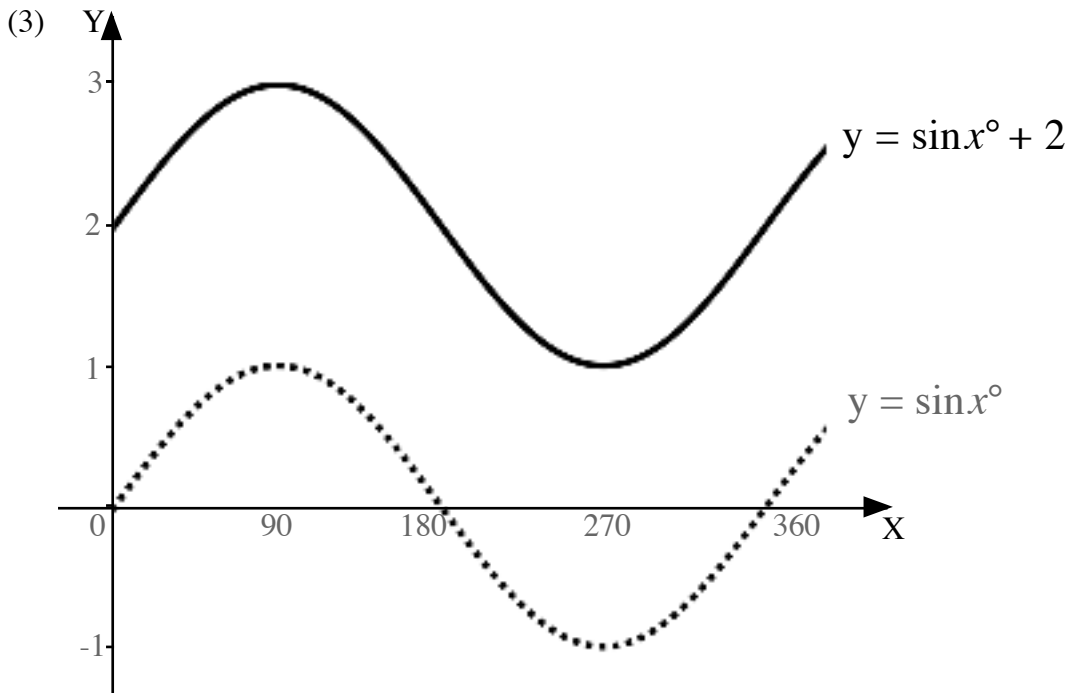

X-SHIFT

$$y = \sin(x + n)^\circ$$

subtract **n** units from the x-coordinates  
graph shifted  $-n^\circ$  horizontally.

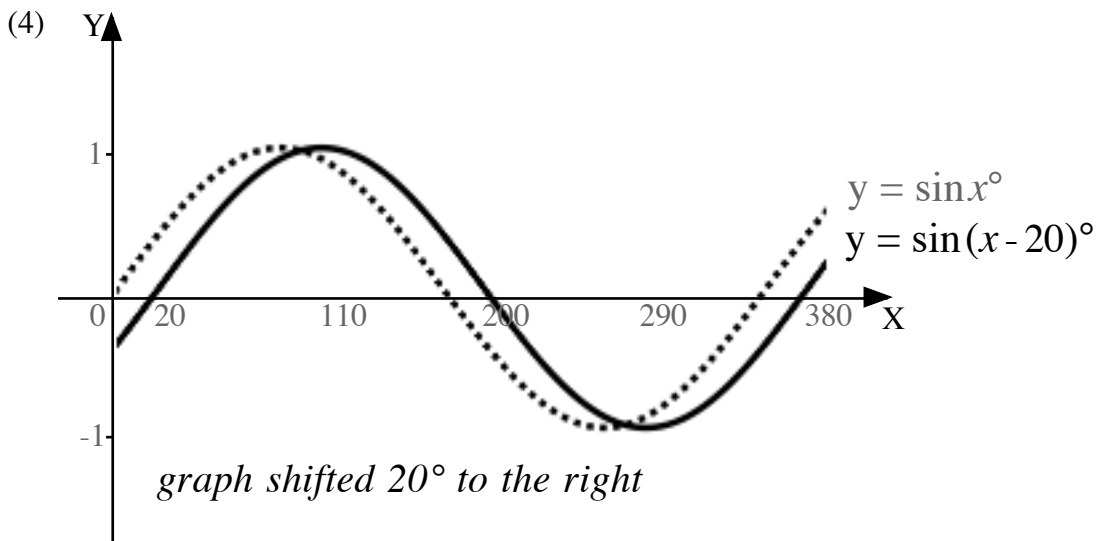

NOTE: for  $y = \sin(x + 20)^\circ$  the graph  $y = \sin x^\circ$  would be shifted  $20^\circ$  to the left.

# COMBINING TRANSFORMATIONS

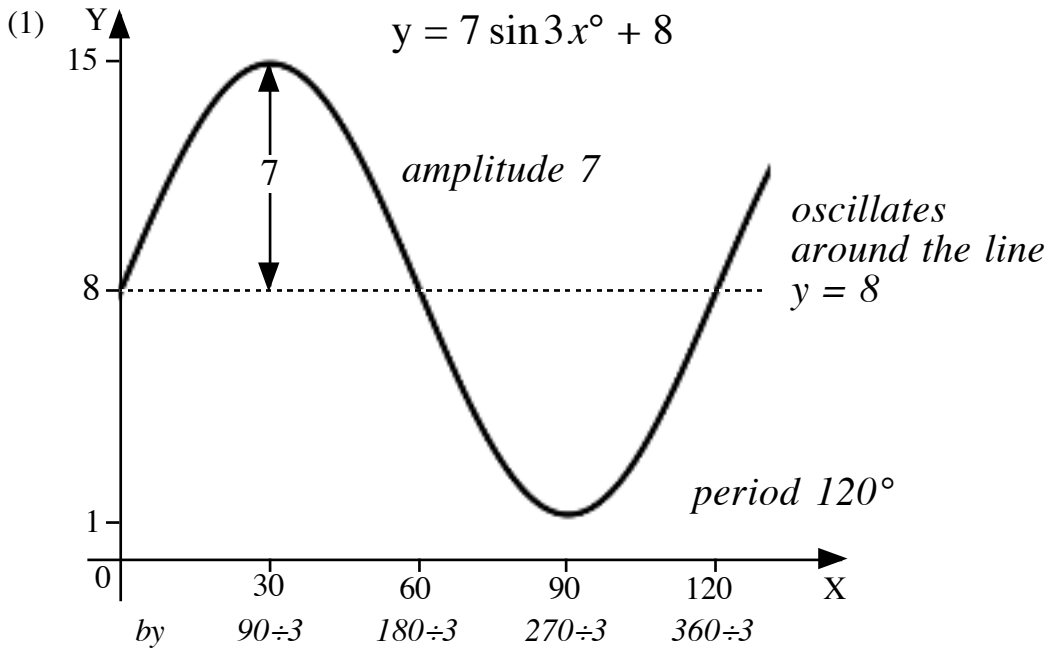

Turning points: maximum  $(30, 15)$  , minimum  $(90, 1)$

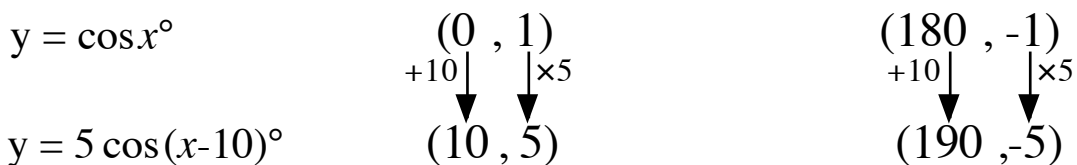
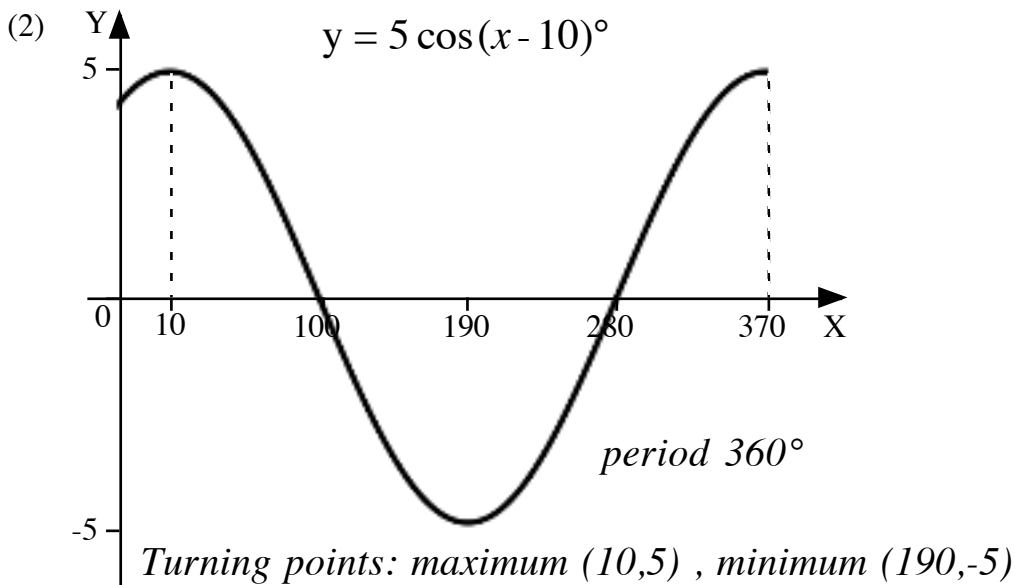
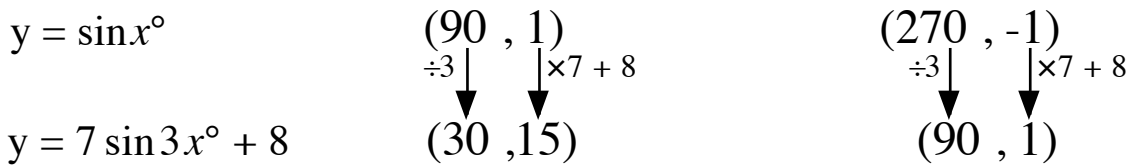



## EQUATIONS

The graphs with equations  $y = 5 + 3 \cos x^\circ$  and  $y = 4$  are shown.  
Find the  $x$  coordinates of the points of intersection A and B.

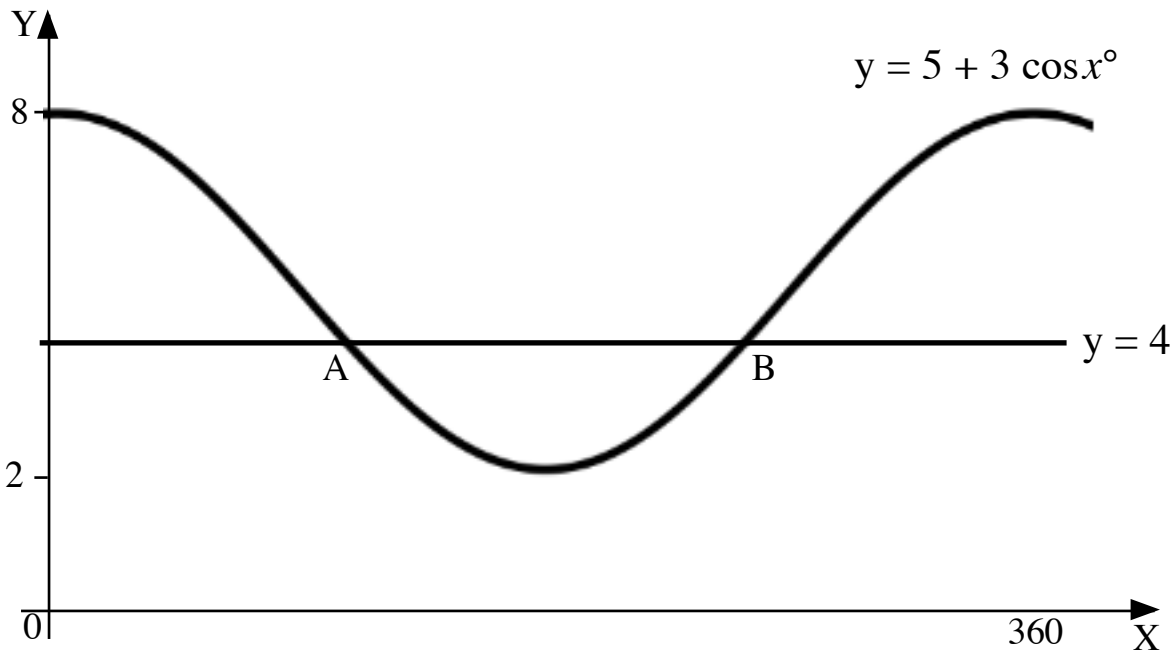

$$5 + 3 \cos x^\circ = 4$$

$$3 \cos x^\circ = -1$$

$$\cos x^\circ = -\frac{1}{3}$$

$$\underline{\underline{x = 109 \cdot 5 \text{ or } 250 \cdot 5}}$$

\* **A, S, T, C** is where functions are **positive**:

S	A
<i>cosine</i> <i>negative</i> ✓	<i>cosine</i> <i>positive</i> ✗
$180 - a = 109 \cdot 5$	$a = \cos^{-1} 1/3 = 70 \cdot 528 \dots$
$180 + a = 250 \cdot 5$	$360 - a = 289 \cdot 5$
<i>cosine</i> <i>negative</i> ✓	<i>cosine</i> <i>positive</i> ✗
T	C

- \* A all functions are positive  
 S sine function only is positive  
 T tangent function only is positive  
 C cosine function only is positive

## IDENTITIES

$$\sin^2 x^\circ + \cos^2 x^\circ = 1$$

$$\tan x^\circ = \frac{\sin x^\circ}{\cos x^\circ}$$

Simplify  $\frac{1 - \cos^2 x^\circ}{\sin x^\circ \cos x^\circ}$ .

$$= \frac{\sin^2 x^\circ}{\sin x^\circ \cos x^\circ}$$

$$= \frac{\sin x^\circ \sin x^\circ}{\sin x^\circ \cos x^\circ}$$

$$= \frac{\sin x^\circ}{\cos x^\circ}$$

$$= \tan x^\circ$$

since  $\sin^2 x^\circ + \cos^2 x^\circ = 1$

$$\sin^2 x^\circ = 1 - \cos^2 x^\circ$$

"cancel"  $\sin x^\circ$

## EXACT VALUES

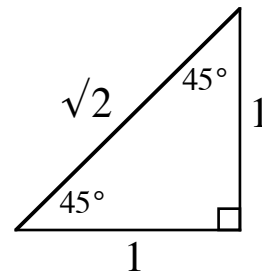
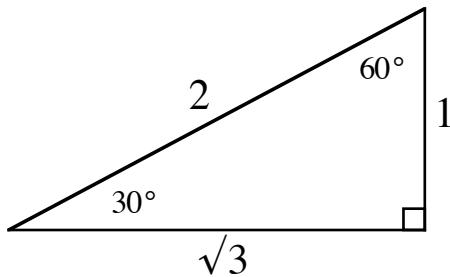

For example,

$$\sin 60^\circ = \frac{\sqrt{3}}{2}, \quad \tan 30^\circ = \frac{1}{\sqrt{3}}$$

$$\cos 45^\circ = \frac{1}{\sqrt{2}}, \quad \tan 45^\circ = \frac{1}{1} = 1$$

## ANGLES > 90°

$$\begin{aligned} &\sin 240^\circ \\ &= \sin(180^\circ + 60^\circ) \\ &= -\sin 60^\circ \\ &= -\frac{\sqrt{3}}{2} \end{aligned}$$

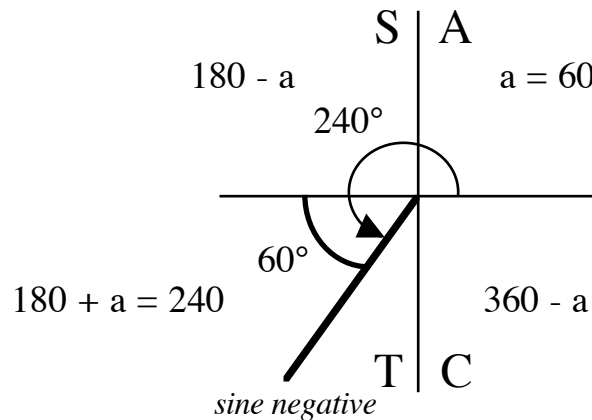

# CHAPTER 18: TRIGONOMETRY: TRIANGLE FORMULAE

## SINE RULE

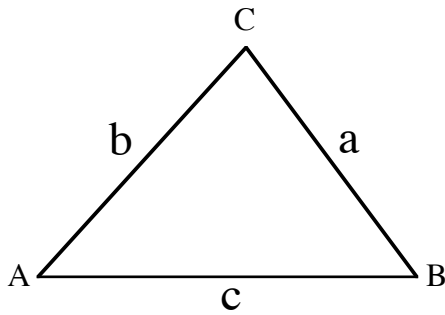

$$\frac{a}{\sin A} = \frac{b}{\sin B} = \frac{c}{\sin C}$$

NOTE: requires at least one side and its opposite angle to be known.

### FINDING AN UNKNOWN SIDE

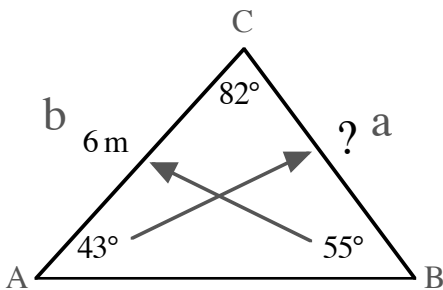

Find the length of side BC

$$\begin{aligned} \frac{a}{\sin A} &= \frac{b}{\sin B} \\ \frac{a}{\sin 43^\circ} &= \frac{6}{\sin 55^\circ} \\ a &= \frac{6}{\sin 55^\circ} \times \sin 43^\circ \\ &= 4.995\dots \\ BC &\approx 5.0 \text{ m} \end{aligned}$$

### FINDING AN UNKNOWN ANGLE

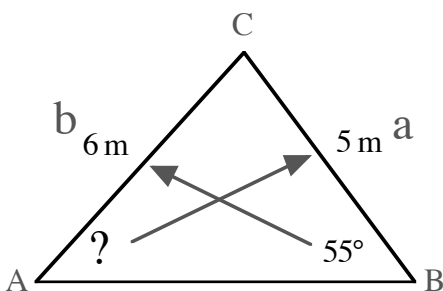

Find the size of angle BAC.

$$\begin{aligned} \frac{\sin A}{a} &= \frac{\sin B}{b} \\ \frac{\sin A}{5} &= \frac{\sin 55^\circ}{6} \\ \sin A &= \frac{\sin 55^\circ}{6} \times 5 \\ &= 0.682\dots \\ A &= \sin^{-1} 0.682\dots \\ &= 43.049\dots \\ \angle BAC &\approx 43.0^\circ \end{aligned}$$

## COSINE RULE

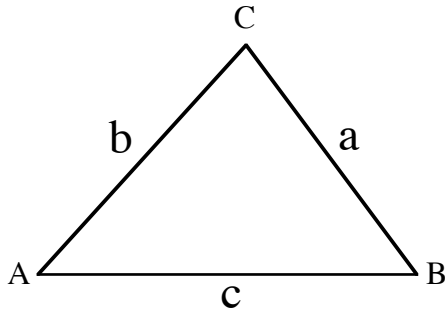

$$a^2 = b^2 + c^2 - 2bc \cos A$$

$$\cos A = \frac{b^2 + c^2 - a^2}{2bc}$$

### FINDING AN UNKNOWN SIDE

NOTE: requires knowing 2 sides and the angle between them.

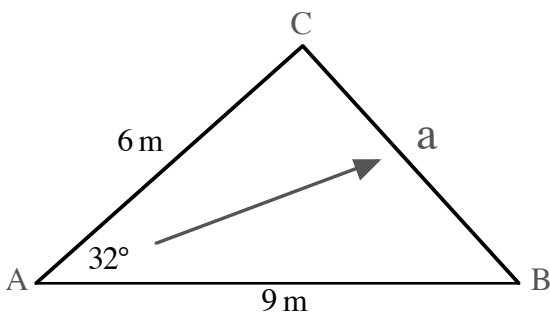

$$a^2 = b^2 + c^2 - 2bc \cos A$$

$$= 6^2 + 9^2 - 2 \times 6 \times 9 \times \cos 32^\circ$$

$$a^2 = 25.410\dots$$

$$a = \sqrt{25.410\dots}$$

$$= 5.040\dots$$

$$BC \approx 5.0 \text{ m}$$

Find the length of side BC.

### FINDING AN UNKNOWN ANGLE

NOTE: requires knowing all 3 sides.

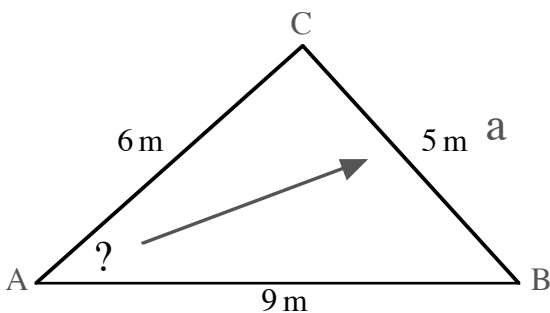

$$\cos A = \frac{b^2 + c^2 - a^2}{2bc}$$

$$= \frac{6^2 + 9^2 - 5^2}{2 \times 6 \times 9}$$

$$\cos A = 0.85185\dots$$

$$A = \cos^{-1}(0.85185\dots)$$

$$= 31.586\dots$$

$$\angle BAC \approx 31.6^\circ$$

Find the size of angle BAC.

# AREA FORMULA

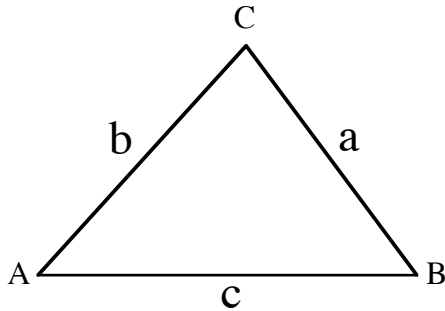

$$\text{Area } \Delta ABC = \frac{1}{2}ab \sin C$$

NOTE: requires knowing 2 sides and the angle between them.

(1)

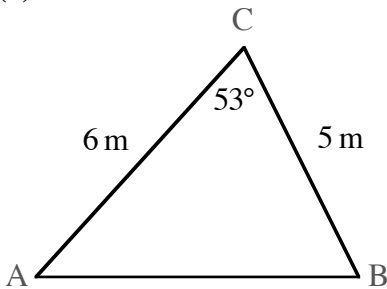

$$\begin{aligned} \text{Area } \Delta ABC &= \frac{1}{2}ab \sin C \\ &= \frac{1}{2} \times 5 \times 6 \times \sin 53^\circ \\ &= 11.979\dots \\ \text{Area} &\approx 12.0 \text{ m}^2 \end{aligned}$$

Find the area of the triangle.

(2)

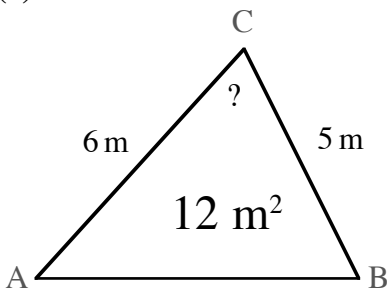

$$\begin{aligned} \text{Area } \Delta ABC &= \frac{1}{2}ab \sin C \\ 12 &= \frac{1}{2} \times 5 \times 6 \times \sin C && \text{double both sides} \\ 24 &= 30 \times \sin C \\ \sin C &= 24 \div 30 = 0.8 \end{aligned}$$

Find angle ACB.

$$\begin{aligned} C &= \sin^{-1}(0.8) \\ &= 53.130\dots^\circ \quad \text{or} \quad 126.869\dots^\circ \\ &\quad \text{(from } 180^\circ - 53.130\dots^\circ \\ &\quad \text{as angle could be obtuse)} \end{aligned}$$

$$\angle ACB \approx 53.1^\circ \quad \text{from diagram, angle acute}$$

# CHAPTER 19: VECTORS

SCALAR quantities have size(magnitude).

eg. time, speed, volume

VECTOR quantities have **size** and **direction**.

eg. force, velocity

A **directed line segment** represents a vector.

Vectors can be written in component form as **column vectors**

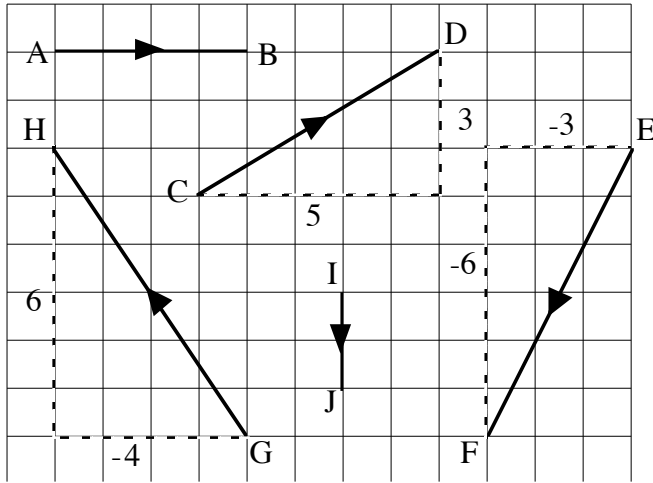

$$\vec{AB} = \begin{pmatrix} 4 \\ 0 \end{pmatrix} \quad \vec{CD} = \begin{pmatrix} 5 \\ 3 \end{pmatrix} \quad \vec{EF} = \begin{pmatrix} -3 \\ -6 \end{pmatrix}$$

$$\vec{GH} = \begin{pmatrix} -4 \\ 6 \end{pmatrix} \quad \vec{IJ} = \begin{pmatrix} 0 \\ -2 \end{pmatrix}$$

*negative vector, opposite direction*

$$\vec{HG} = \begin{pmatrix} 4 \\ -6 \end{pmatrix}$$

**SIZE** follows from Pyth. Thm

$$\mathbf{u} = \begin{pmatrix} a \\ b \end{pmatrix}$$

$$|\mathbf{u}| = \sqrt{a^2 + b^2}$$

$$|\vec{GH}| = \sqrt{(-4)^2 + 6^2} = \sqrt{52} = 2\sqrt{13} \text{ units}$$

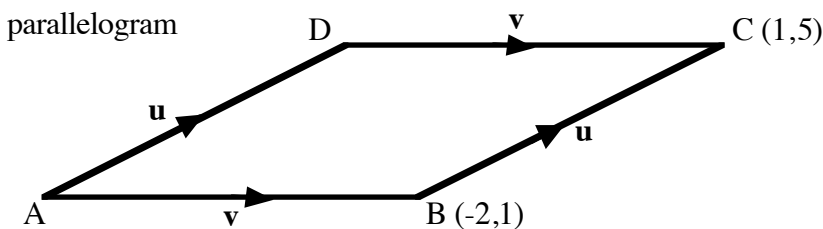

$$\vec{AD} = \vec{BC} = \begin{pmatrix} 3 \\ 4 \end{pmatrix}$$

same size and direction  
same vector **u**  
same component form

## ADD/SUBTRACT

**by column vectors**

add or subtract components.

$$\begin{pmatrix} -3 \\ 4 \end{pmatrix} + \begin{pmatrix} 7 \\ 2 \end{pmatrix} = \begin{pmatrix} 4 \\ 6 \end{pmatrix}$$

**by diagram**

“head-to-tail” addition

$$\vec{PQ} + \vec{QR} = \vec{PR}$$

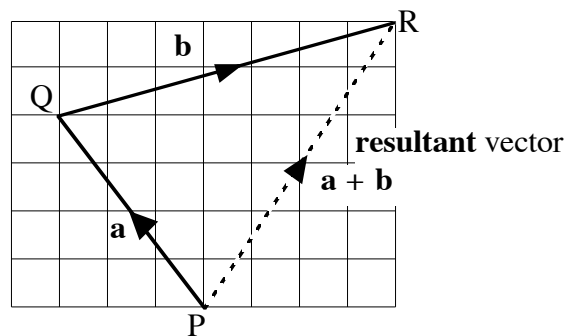

**MULTIPLY** by a number

$$\mathbf{u} = \begin{pmatrix} a \\ b \end{pmatrix} \quad k\mathbf{u} = \begin{pmatrix} ka \\ kb \end{pmatrix}$$

$$\vec{AB} = \begin{pmatrix} 2 \\ 1 \end{pmatrix} \quad \vec{CD} = \begin{pmatrix} 8 \\ 4 \end{pmatrix}$$

if  $\mathbf{v} = k\mathbf{u}$

$$\vec{CD} = 4\vec{AB}$$

then  $\mathbf{u}$  and  $\mathbf{v}$  are parallel

$CD$  is parallel to  $AB$

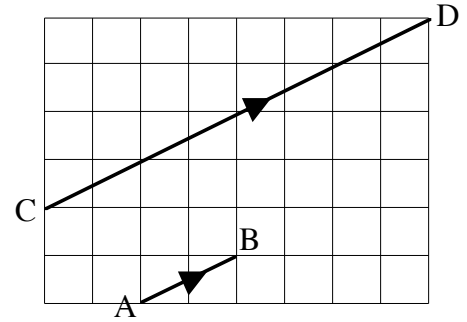

### 3D

Vectors in 3D operate in the same way as vectors in 2D.

Points are plotted on 3 mutually perpendicular axes.

$P(x,y,z)$  has **position vector**  $\mathbf{p} = \begin{pmatrix} x \\ y \\ z \end{pmatrix}$

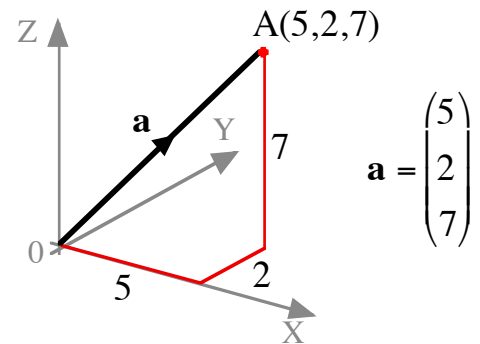

If  $\mathbf{u} = \begin{pmatrix} 1 \\ -2 \\ 3 \end{pmatrix}$  and  $\mathbf{v} = \begin{pmatrix} -1 \\ 0 \\ 1 \end{pmatrix}$  find the value of  $|\mathbf{v} - 2\mathbf{u}|$ .

$$\mathbf{v} - 2\mathbf{u} = \begin{pmatrix} -1 \\ 0 \\ 1 \end{pmatrix} - 2\begin{pmatrix} 1 \\ -2 \\ 3 \end{pmatrix} = \begin{pmatrix} -1 \\ 0 \\ 1 \end{pmatrix} - \begin{pmatrix} 2 \\ -4 \\ 6 \end{pmatrix} = \begin{pmatrix} -3 \\ 4 \\ -5 \end{pmatrix}$$

$$|\mathbf{v} - 2\mathbf{u}| = \sqrt{(-3)^2 + 4^2 + (-5)^2} = \sqrt{50} = 5\sqrt{2}$$

# CHAPTER 20: STATISTICS

Studying statistical information, it is useful to consider: (1) typical result: **average**  
 (2) distribution of results: **spread**

## AVERAGES:

$$\text{mean} = \frac{\text{total of all results}}{\text{number of results}}$$

*median = middle result of the ordered results*

*mode = most frequent result*

## SPREAD:

Ordered results are split into 4 equal groups so each contains 25% of the results.

The **5 figure summary** identifies:  $L, Q_1, Q_2, Q_3, H$   
 (lowest result, 1st, 2nd and 3rd quartiles, highest result)

A **Box Plot** is a statistical diagram that displays the 5 figure summary:

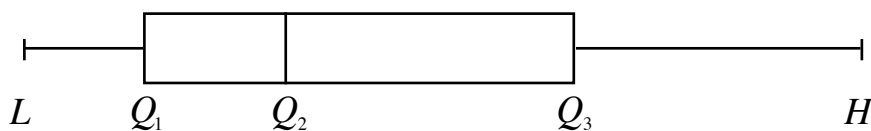

$$\text{range, } R = H - L$$

$$\text{interquartile range, } IQR = Q_3 - Q_1$$

$$\text{semi-interquartile range, } SIQR = \frac{Q_3 - Q_1}{2}$$

NOTE: If  $Q_1, Q_2$  or  $Q_3$  fall between two results, the mean of the two results is taken.

For example,

12 ordered results: split into 4 equal groups of 3 results

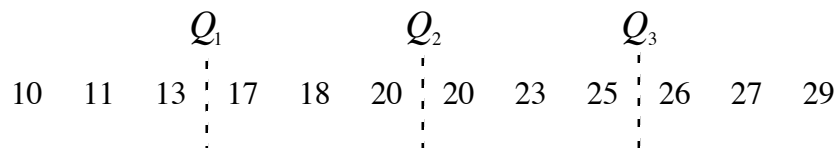

$$Q_1 = \frac{13 + 17}{2} = 15, \quad Q_2 = \frac{20 + 20}{2} = 20, \quad Q_3 = \frac{25 + 26}{2} = 25.5$$



The pulse rates of school students were recorded in Biology class.

Pulse rates: 66, 64, 71, 56, 60, 79, 77, 75, 69, 73, 75, 62, 66, 71, 66 beats per minute.

**15 ordered results:**

56 60 62  $Q_1$  64 66 66 66  $Q_2$  69 71 71 73  $Q_3$  75 75 77 79

**5 Figure Summary:**

$L = 56$  ,  $Q_1 = 64$  ,  $Q_2 = 69$  ,  $Q_3 = 75$  ,  $H = 79$

**Box Plot:**

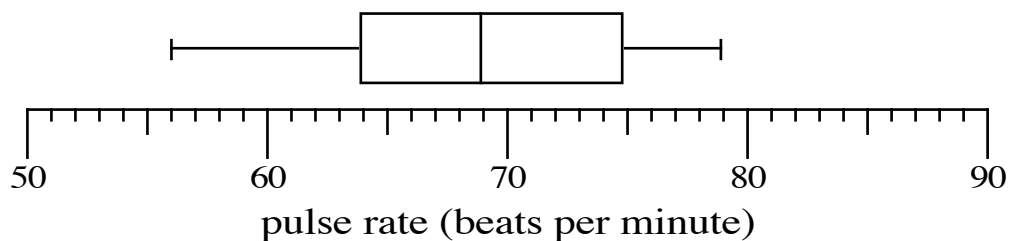

**Spread:**

$$R = H - L = 79 - 56 = 23$$

$$IQR = Q_3 - Q_1 = 75 - 64 = 11$$

$$SIQR = \frac{Q_3 - Q_1}{2} = \frac{75 - 64}{2} = \frac{11}{2} = 5.5$$

**Averages:** ( $total = 66 + 64 + 71 + \dots + 66 = 1030$ )

$$MEAN = \frac{1030}{15} = 68.666\dots = 68.7$$

$$(Q_2)MEDIAN = 69$$

$$MODE = 66$$

# STANDARD DEVIATION

A measure of the spread of a set of data, giving a numerical value to how the data deviates from the mean. It therefore gives an indication of how good the mean is as a representative of the data set.

## Formulae:

mean  $\bar{x} = \frac{\sum x}{n}$       standard deviation  $s = \sqrt{\frac{\sum (x - \bar{x})^2}{n - 1}}$       or       $s = \sqrt{\frac{\sum x^2 - \frac{(\sum x)^2}{n}}{n - 1}}$

Examples,

(1) High Standard Deviation: results spread out

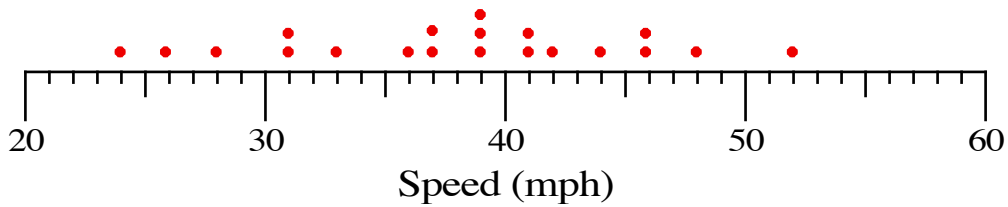

mean = 38 , standard deviation = 7.5

(2) Low Standard Deviation: results clustered around the mean  
the results are more consistent

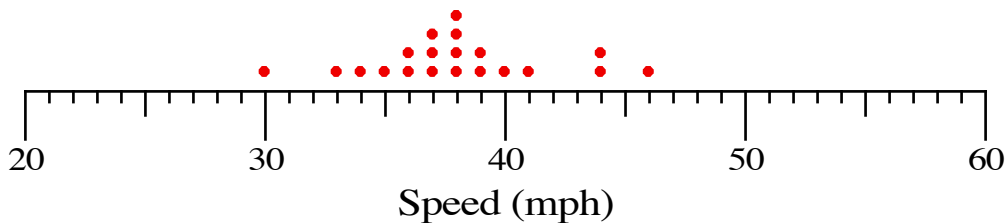

mean = 38 , standard deviation = 3.8

The pulse rates of 8 army recruits: 61, 64, 65, 67, 70, 72, 75, 78 beats per minute.

$$\begin{aligned}\bar{x} &= \frac{\sum x}{n} \\ &= \frac{552}{8} \\ &= 69\end{aligned}$$

$x$	$x - \bar{x}$	$(x - \bar{x})^2$
61	-8	64
64	-5	25
65	-4	16
67	-2	4
70	+1	1
72	+3	9
75	+6	36
78	+9	81
TOTALS	552	236

$$\begin{aligned}s &= \sqrt{\frac{\sum (x - \bar{x})^2}{n - 1}} \\ &= \sqrt{\frac{236}{7}} \\ &= 5.806\dots \\ &\approx 5.8\end{aligned}$$

Or

$$\begin{aligned}\bar{x} &= \frac{\sum x}{n} \\ &= \frac{552}{8} \\ &= 69\end{aligned}$$

$x$	$x^2$	
61	3721	
64	4096	
65	4225	
67	4489	
70	4900	
72	5184	
75	5625	
78	6084	
TOTALS	552	38324

$$\begin{aligned}s &= \sqrt{\frac{\sum x^2 - \frac{(\sum x)^2}{n}}{n - 1}} \\ &= \sqrt{\frac{38324 - \frac{552^2}{8}}{7}} \\ &= \sqrt{\frac{236}{7}} \\ &= 5.806\dots \\ &\approx 5.8\end{aligned}$$

# PROBABILITY

The probability of an event A occurring is  $P(A) = \frac{\text{number of outcomes involving A}}{\text{total number of outcomes possible}}$

$0 \leq P \leq 1$        $P = 0$  impossible      ,       $P = 1$  certain

$$P(\text{not A}) = 1 - P(A)$$

number of expected outcomes involving event A = number of trials  $\times$   $P(A)$

The experimental results will differ from the theoretical probability.

- (1) In an experiment a letter is chosen at random from the word ARITHMETIC and the results recorded.

letter	frequency	relative frequency
vowel	111	$111 \div 300 = 0.37$
consonant	189	$189 \div 300 = 0.63$
	total = 300	total = 1

Estimate of probability,

$$P(\text{vowel}) = 0.37$$

- (2) A letter is chosen at random from the word ARITHMETIC.

4 vowels out of 10 letters,  $P(\text{vowel}) = \frac{4}{10} = \frac{2}{5}$       ie. 0.4

for 300 trials,  $\text{number of vowels expected} = \text{number of trials} \times P(\text{vowel})$   
 $= 300 \times 0.4$   
 $= 120$

6 consonants out of 10 letters,  $P(\text{consonant}) = \frac{6}{10} = \frac{3}{5}$       ie. 0.6

$$P(\text{not a vowel}) = 1 - 0.4 = 0.6$$

vowel **or** consonant,

$$P(\text{either}) = \frac{10}{10} = 1 \quad \text{certain}$$

vowel **and** consonant,

$$P(\text{both}) = \frac{0}{10} = 0 \quad \text{impossible}$$